

# STURMEY-ARCHER

## Axle & Indicator Chart

### How to use the Chart.

1. First identify the Axle pattern and Indicator assembly from the "type" diagrams shown by letters AW. AB. AT. AM. AR. AF. FM. K. KB. KT. KSW. KS. TC. TF. and TFB.
2. By laying the axle on the "lengths" diagram with the Key Slots in alignment, the correct Axle number will be found together with its corresponding indicator.

**Drawings are shown actual size**

### Axle Types "K" Pattern

K1 K1<sup>A</sup> K101 K101<sup>A</sup>  
K351 K351<sup>A</sup>

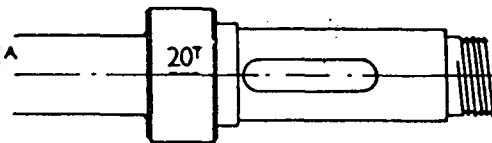

K · KB · KT

K241 K241<sup>A</sup>

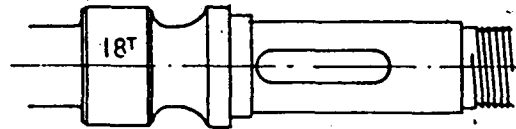

KSW

K201 K201<sup>A</sup>

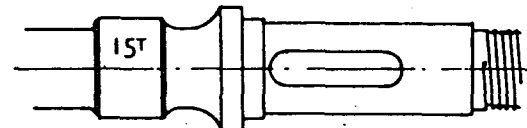

KS · TC

### Indicator Assembly "K" Pattern

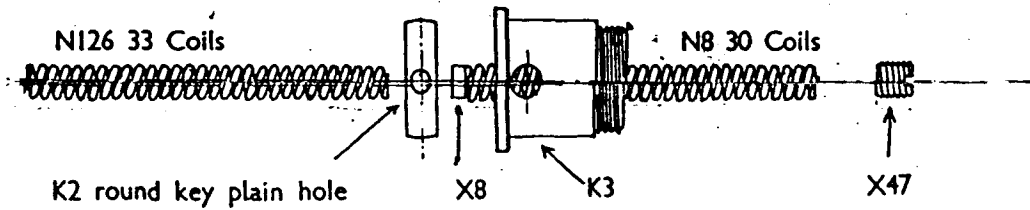

**Axle and Indicator Lengths "K" Pattern**

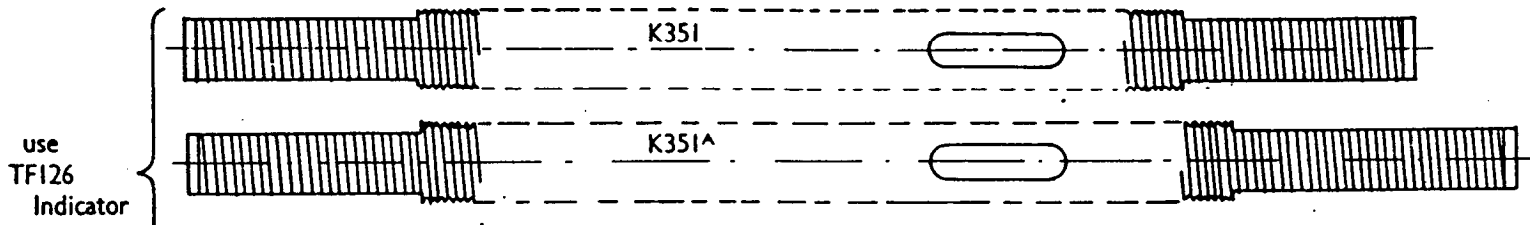
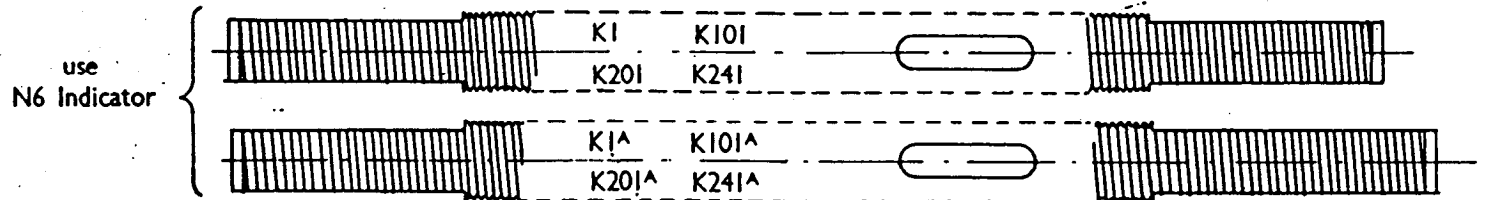

**Axle and Indicator Type and Lengths "TF" Pattern**

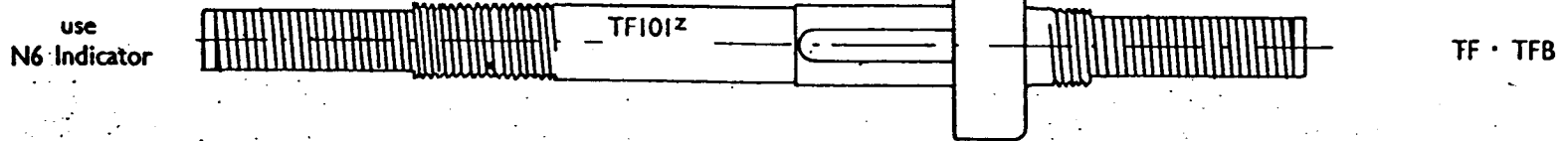
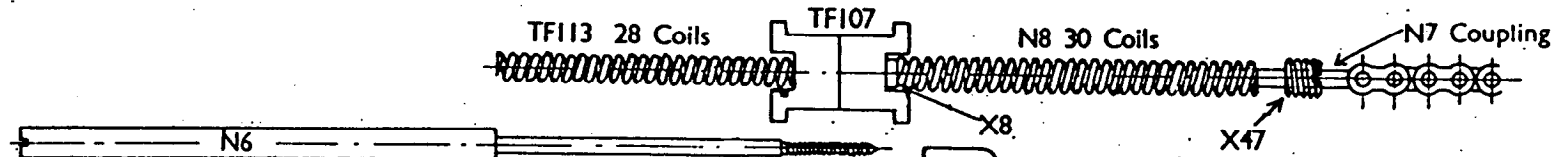
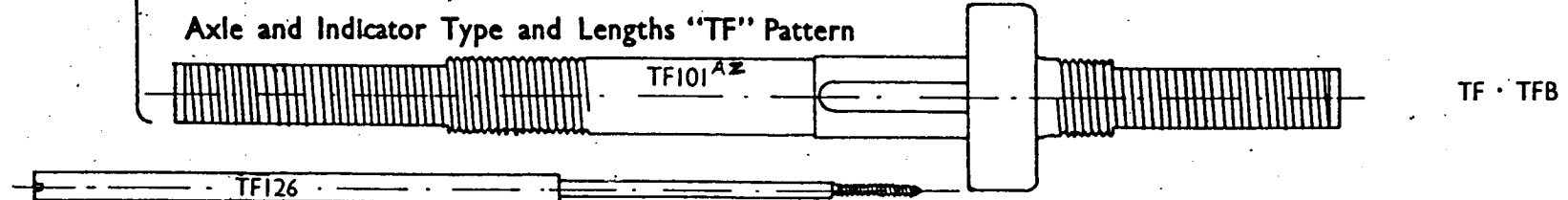

### Axle Types "A" Pattern

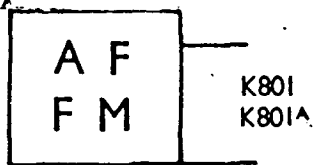
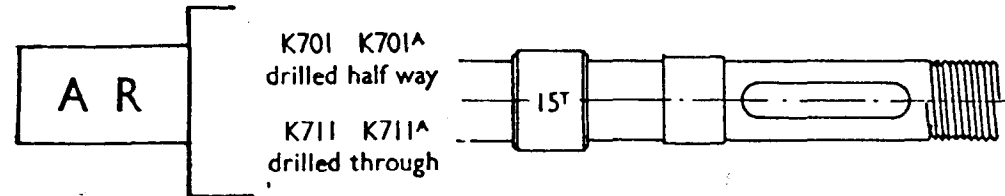
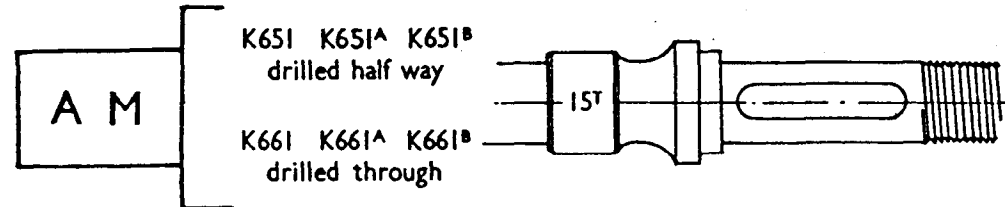
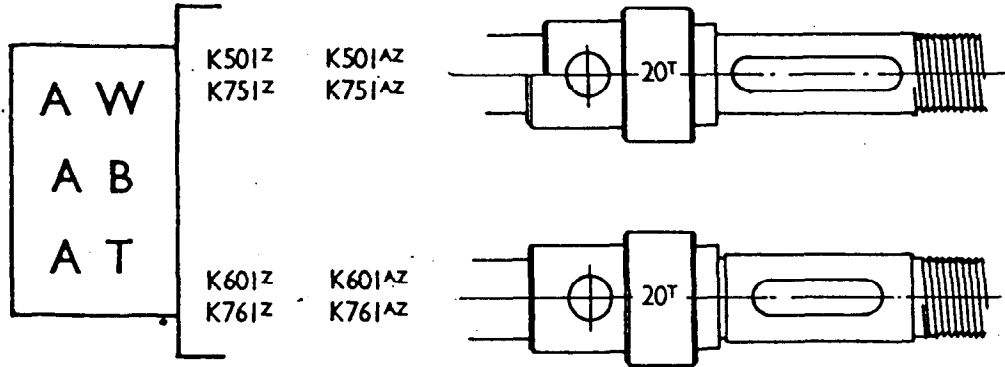

### Indicator Assemblies "A" Pattern

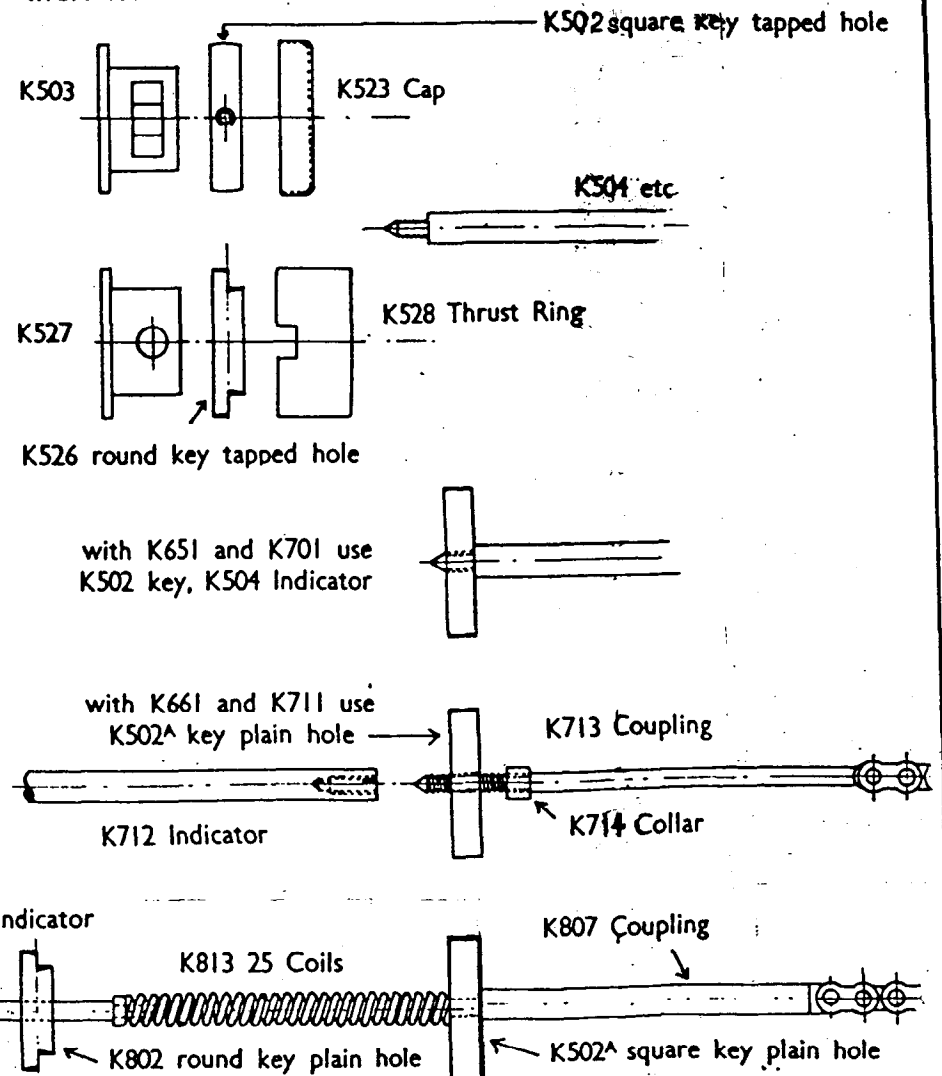

Axle and Indicator Lengths "A" Pattern

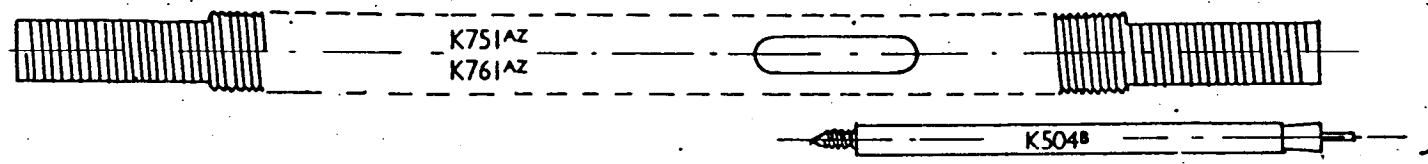
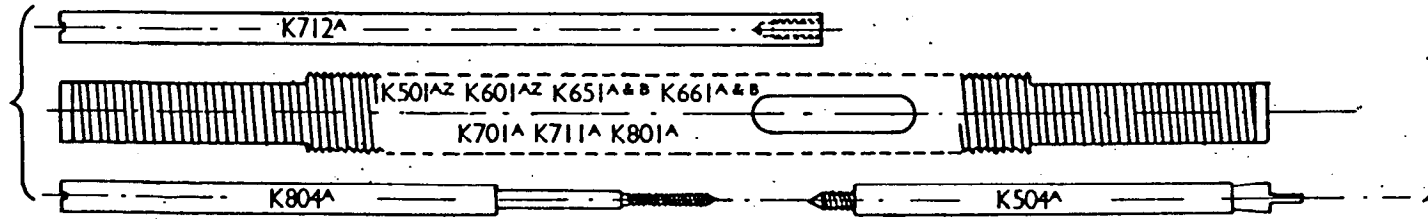
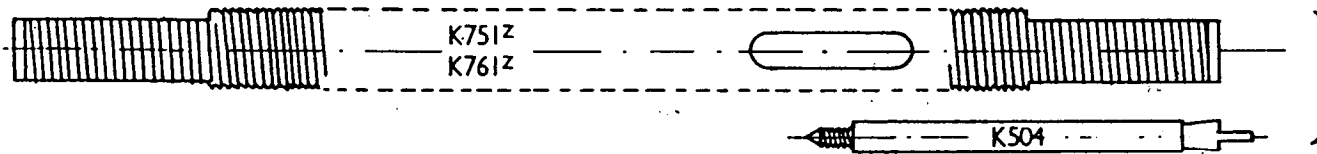
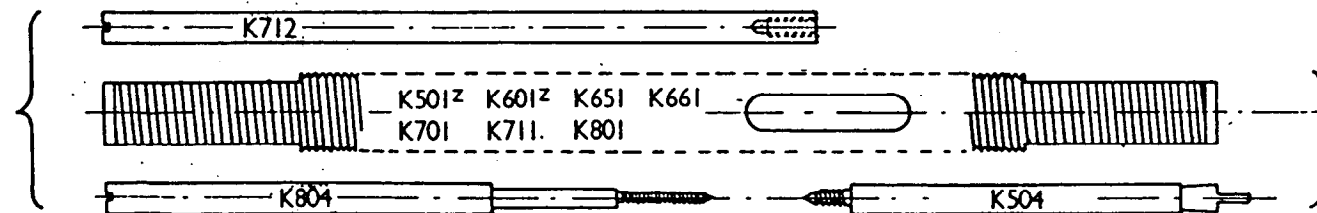

K351 K351A K651B K661B K751Z K751AZ Axles are NCCH Steel  
and are distinguished by two drill marks or dots



# AXLE LAY-ON CHART

## THREE SPEED HUBS

AW AXLE - SHORT

K6012 HSA 107

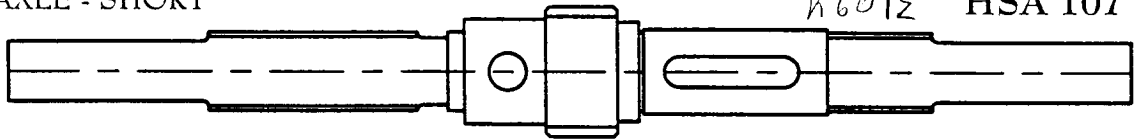

AW AXLE - LONG

ABC AXLE - UNTIL 6/89

HSA 370

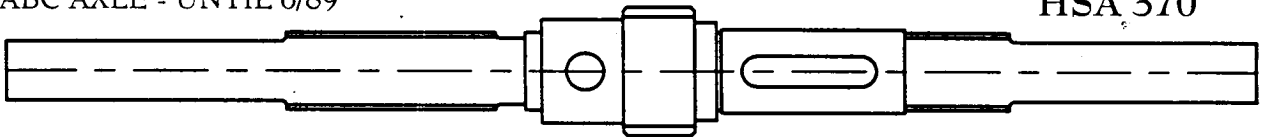

SAB AXLE 6/89 - 4/92

AT3 AXLE 6/89 - 1/93

ABC AXLE 6/89 - 10/93

HSA 440

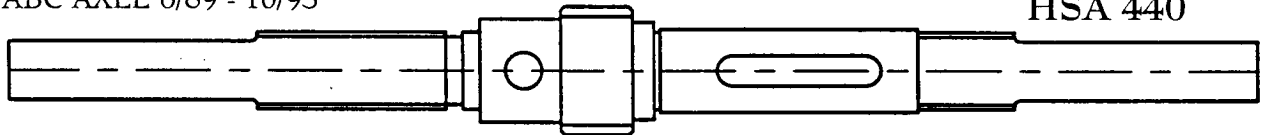

SAB AXLE FROM 4/92

AT3 AXLE FROM 1/93

ABC AXLE FROM 10/93

HSA 471

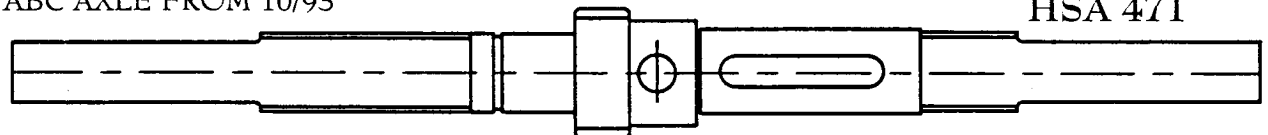

AWC COASTER AXLE

HSA 467

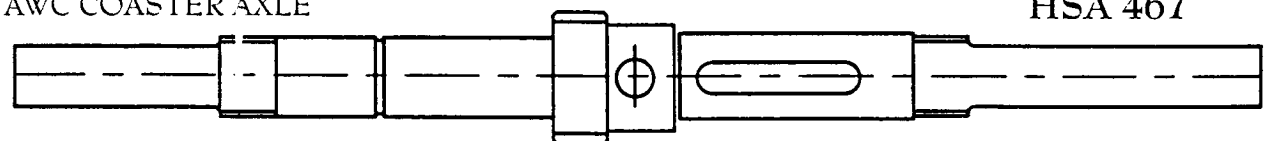

ACTUAL SIZE AXLES



# AXLE LAY-ON CHART

## FIVE SPEED HUBS

S5 AXLE  
AT5 AXLE UNTIL 8/88

HSA 341

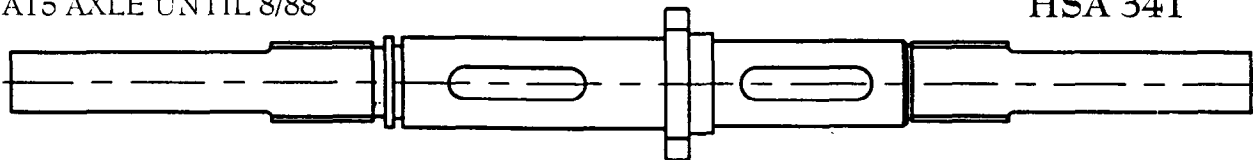

S5 AXLE  
AT5 AXLE FROM 8/88

HSA 424

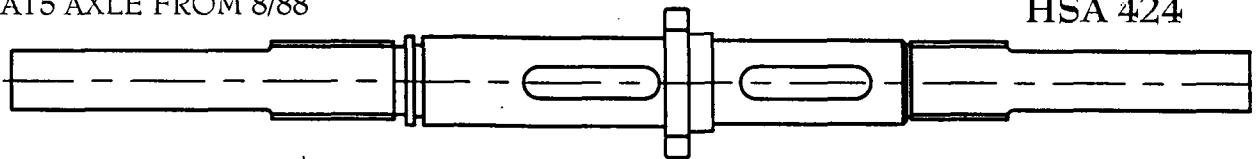

S5 AXLE  
AT5 AXLE 5-STAR 1/91 TO 7/93

HSA 462



S5 AXLE  
AT5 AXLE SPRINTER FROM 7/93

HSA 484

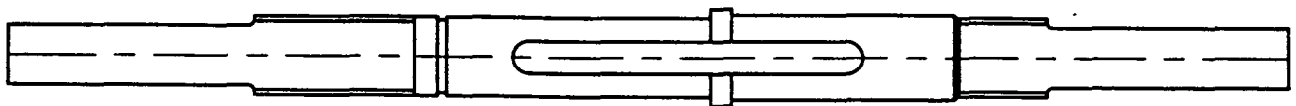

S5C COASTER AXLE FROM 7/93

HSA 505

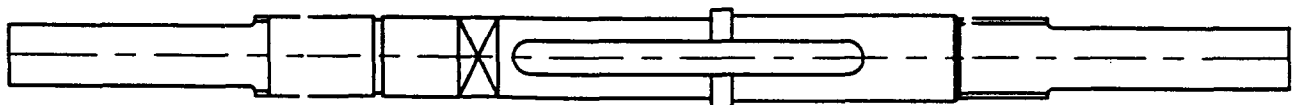

ACTUAL SIZE AXLES

# AXLE CHARTS FOR 3- AND 4-SPEED HUBS

1922 - 1939.

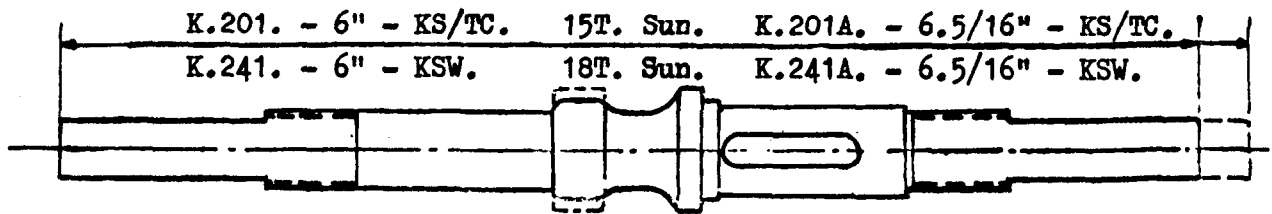

KS KSW TC

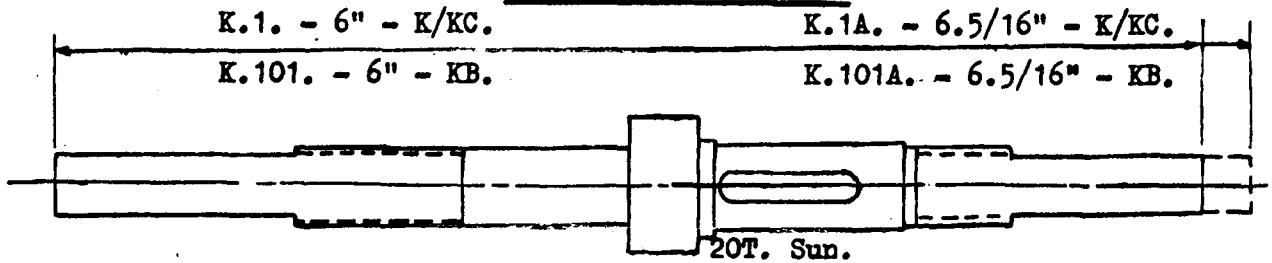

K KB KC

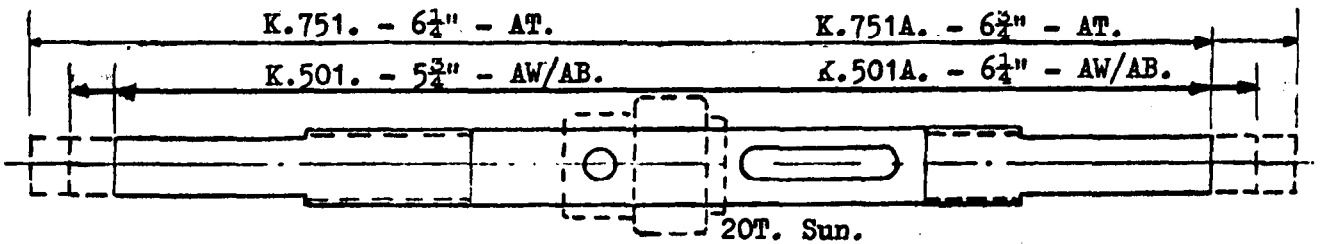

AW AB AT

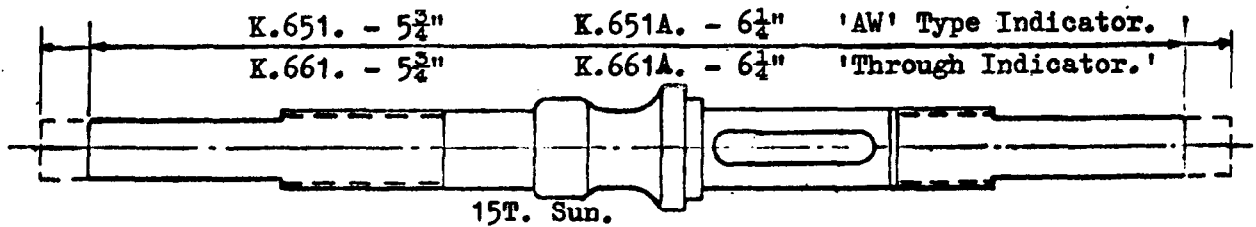

AM

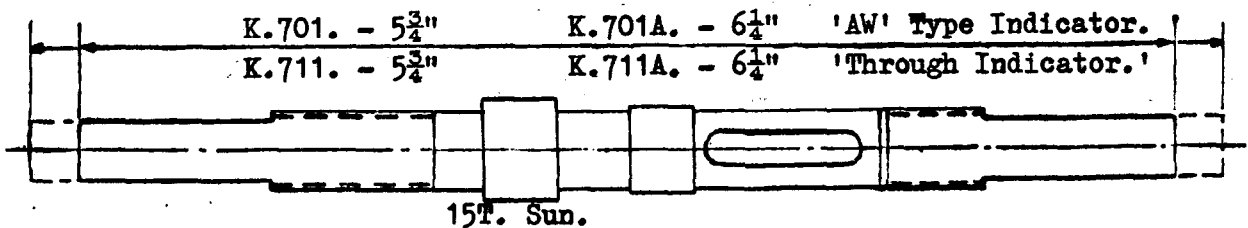

AR

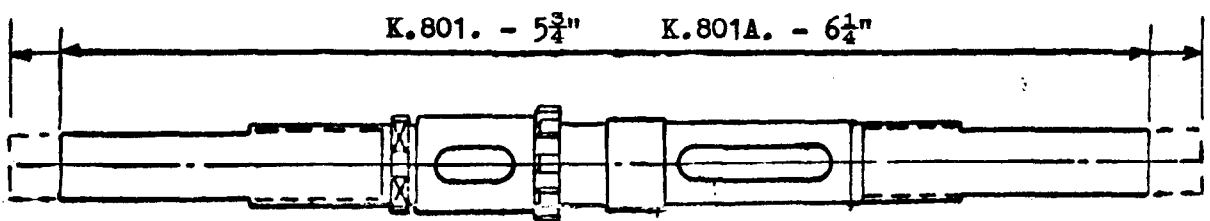

AF FM



# AXLE CHARTS FOR 3- AND 4-SPEED HUBS

1940 - 1958.

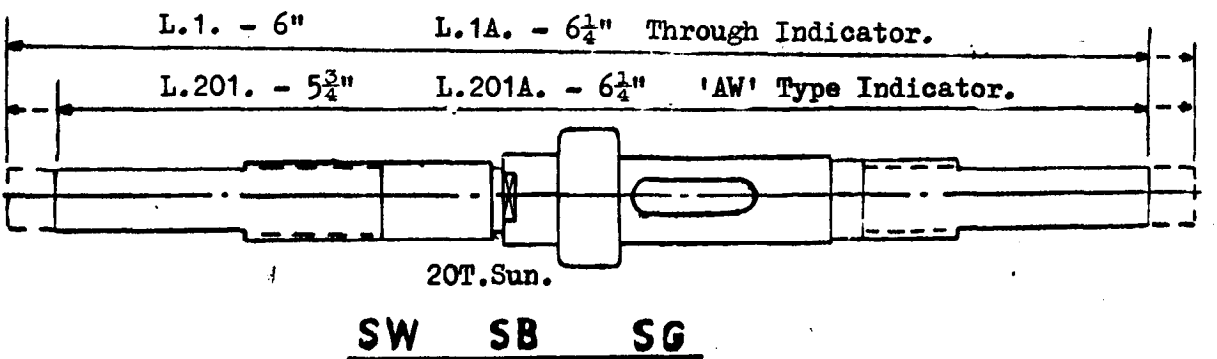
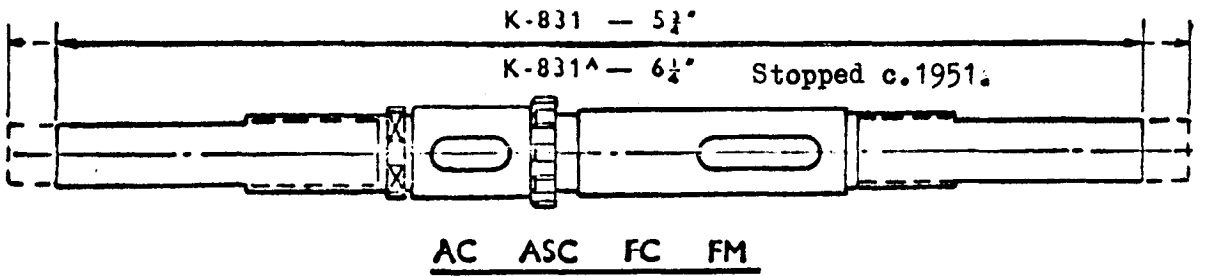
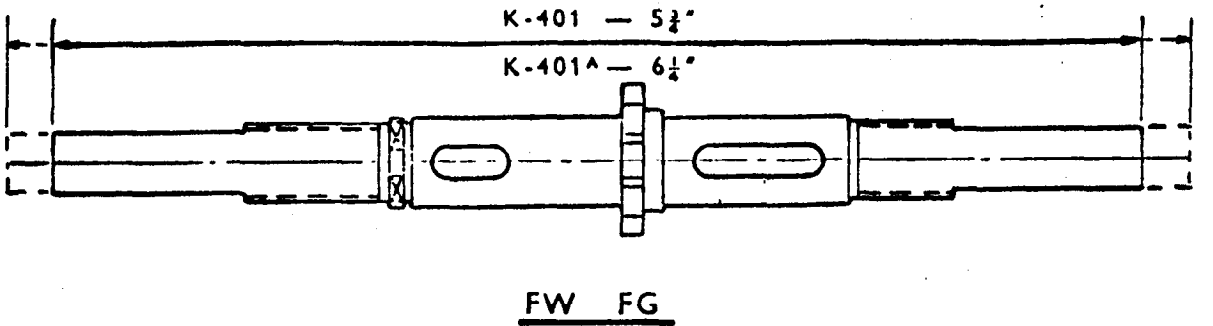
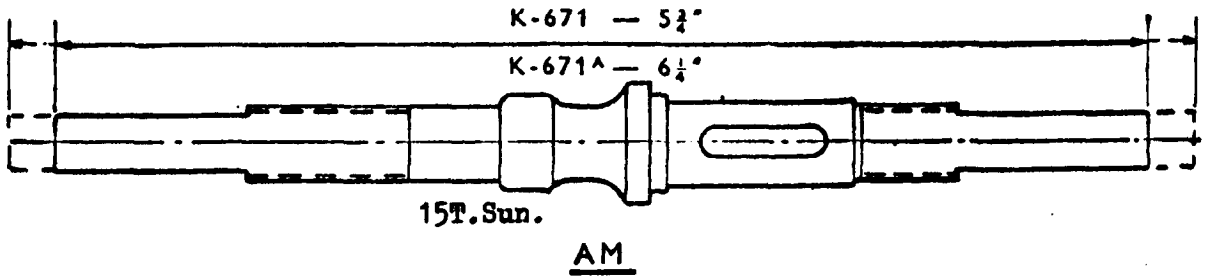
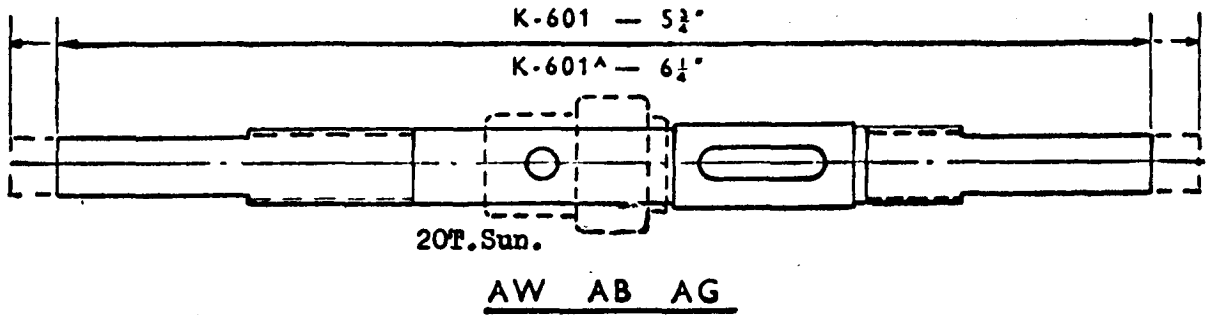
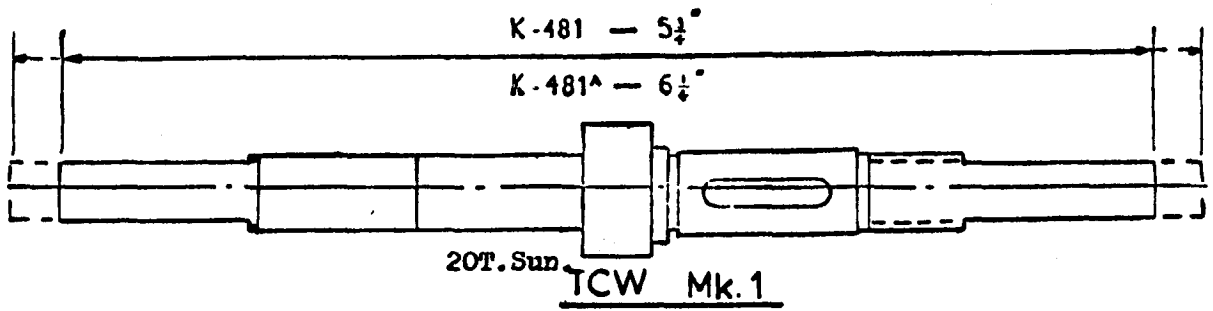

# MODEL 'X' AXLES.

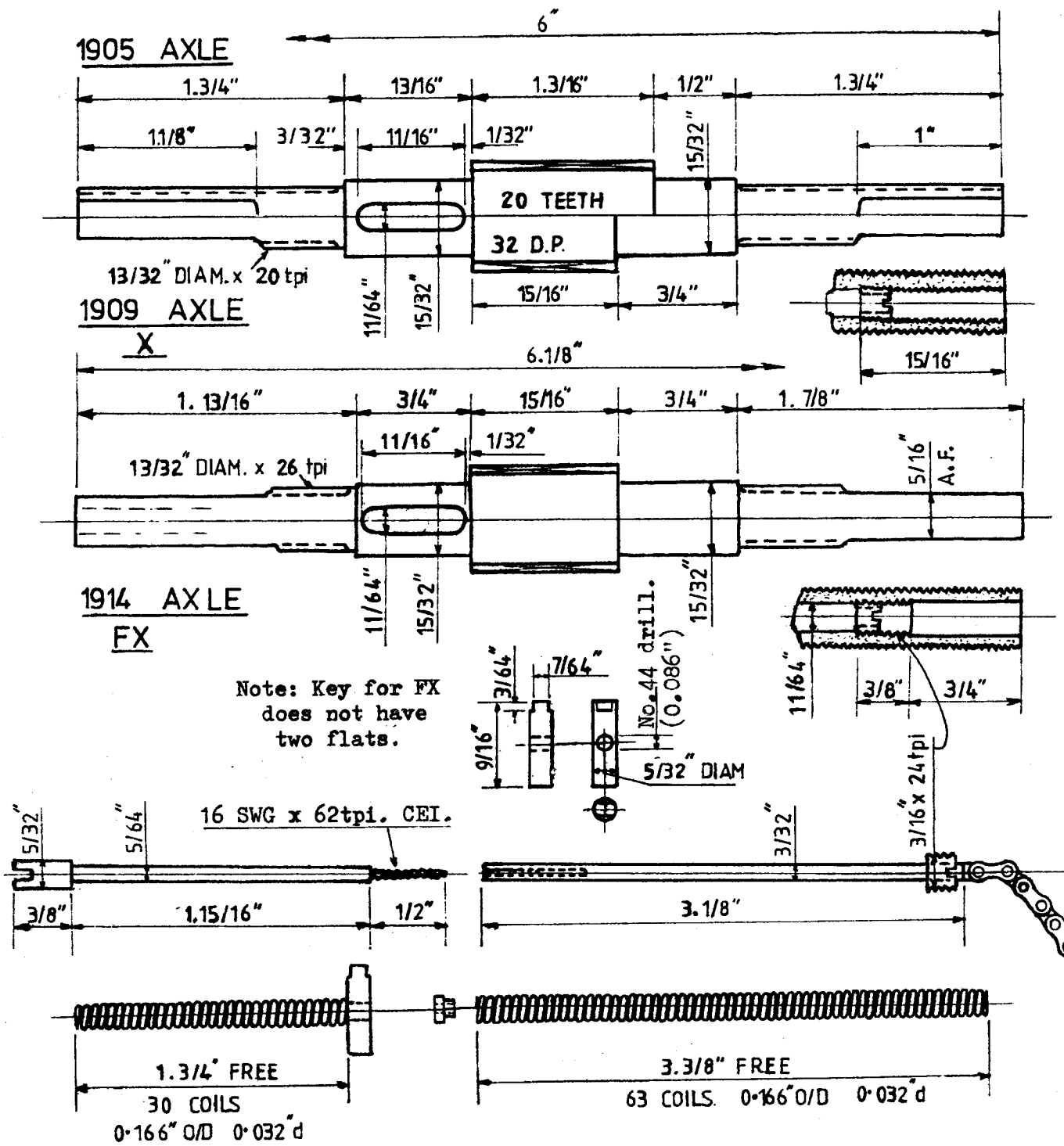

FULL SIZE

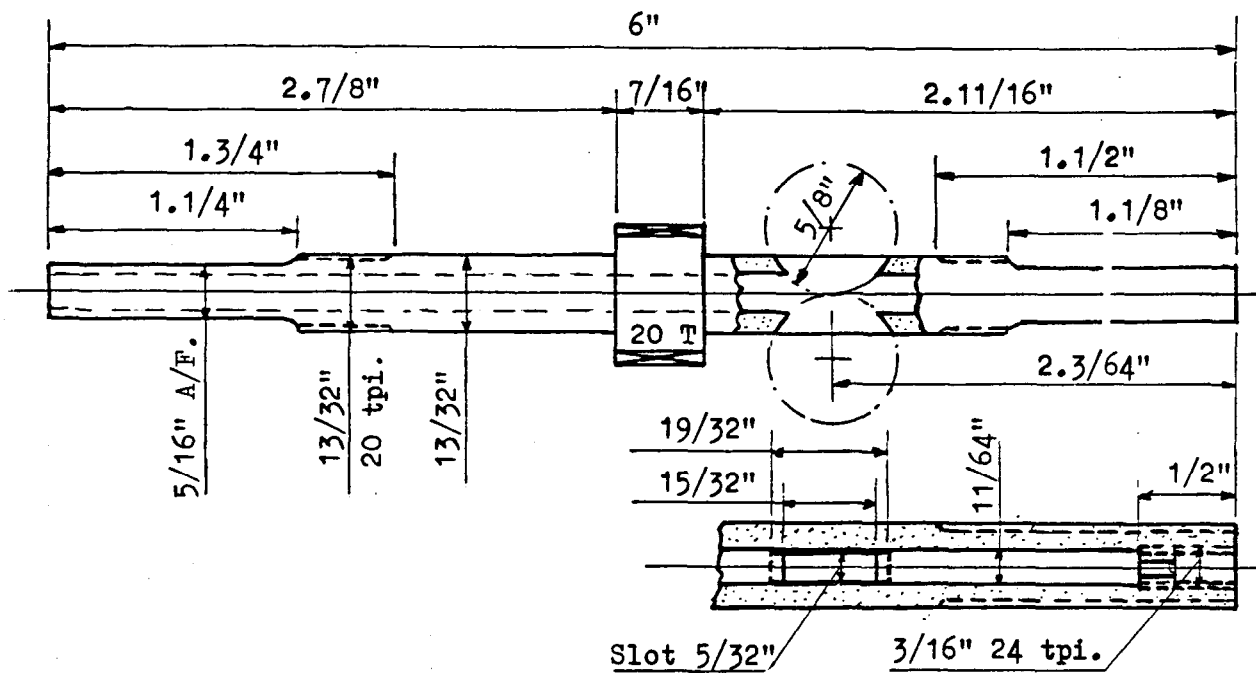

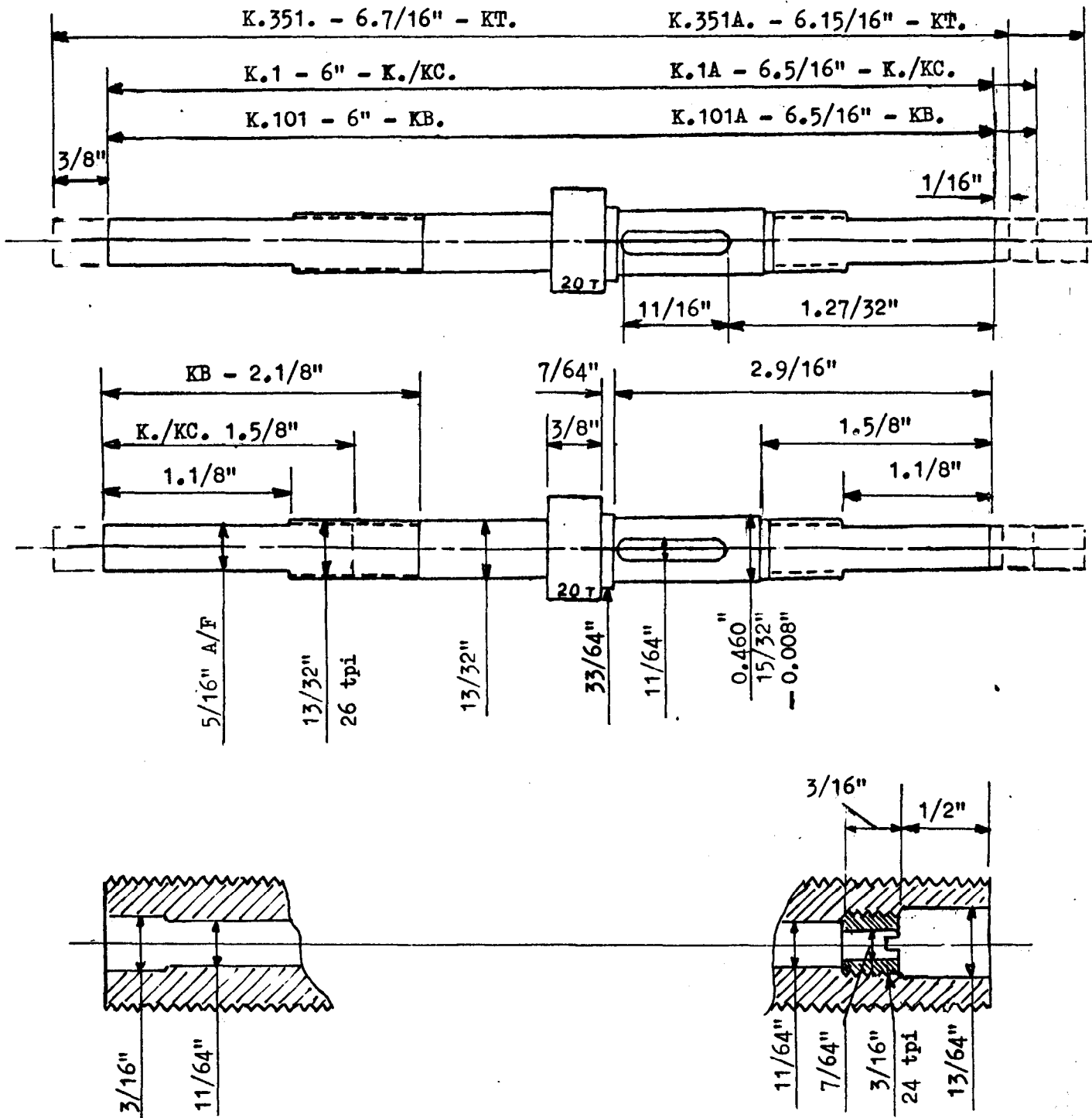

Axles drilled for Left hand indicator.

KS. KSW. TC.

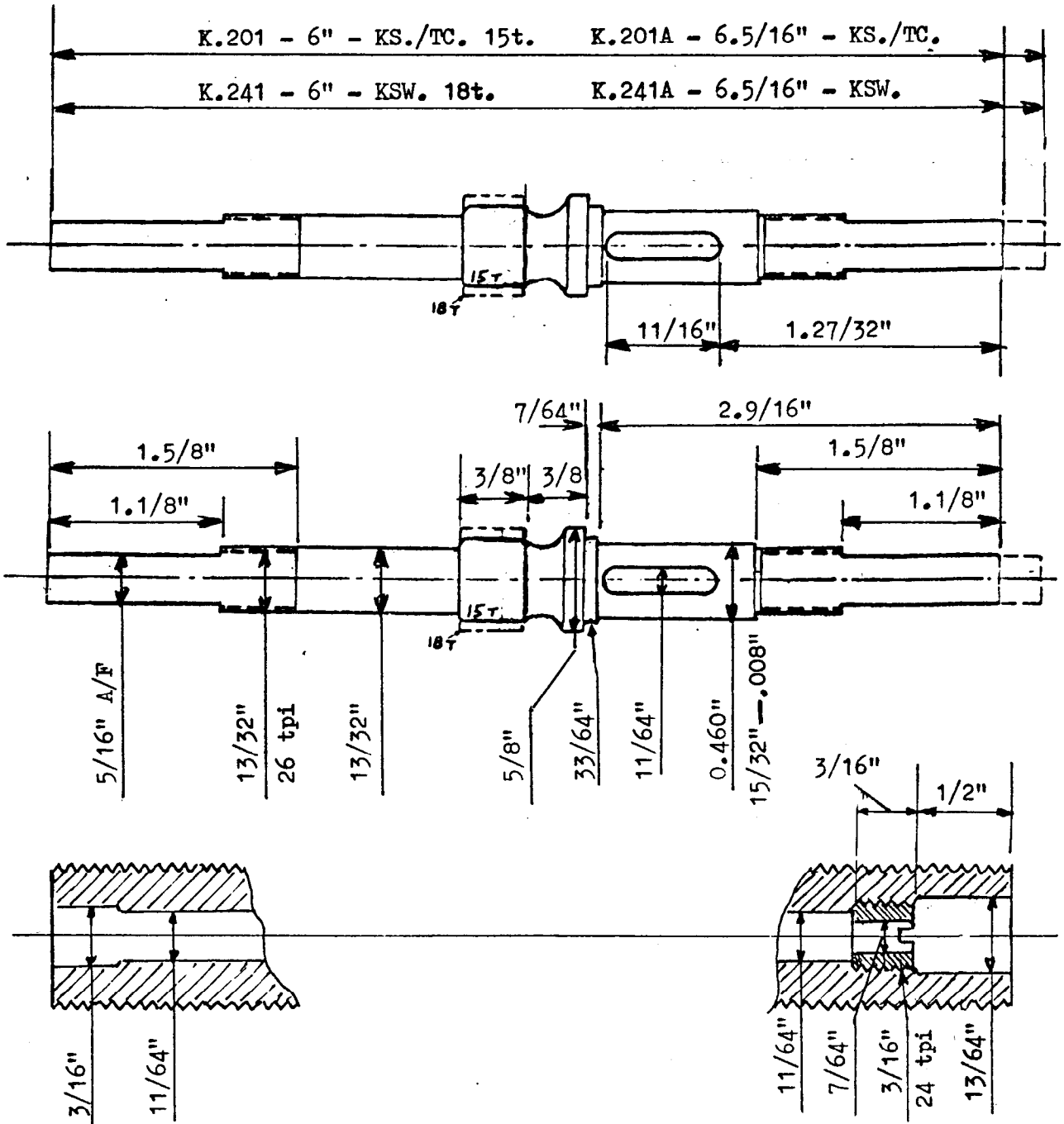

Axles drilled for Left hand indicator.

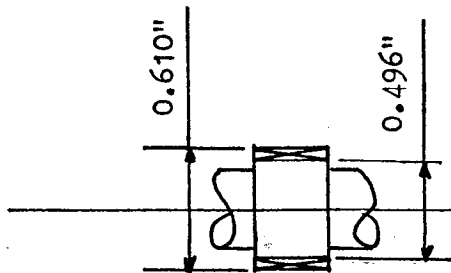

18T Sun.  
KSW.

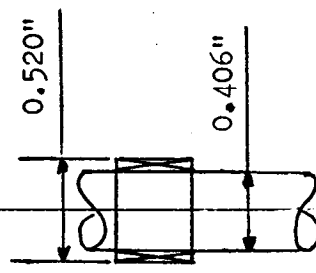

15T Sun.  
KS.

TC.

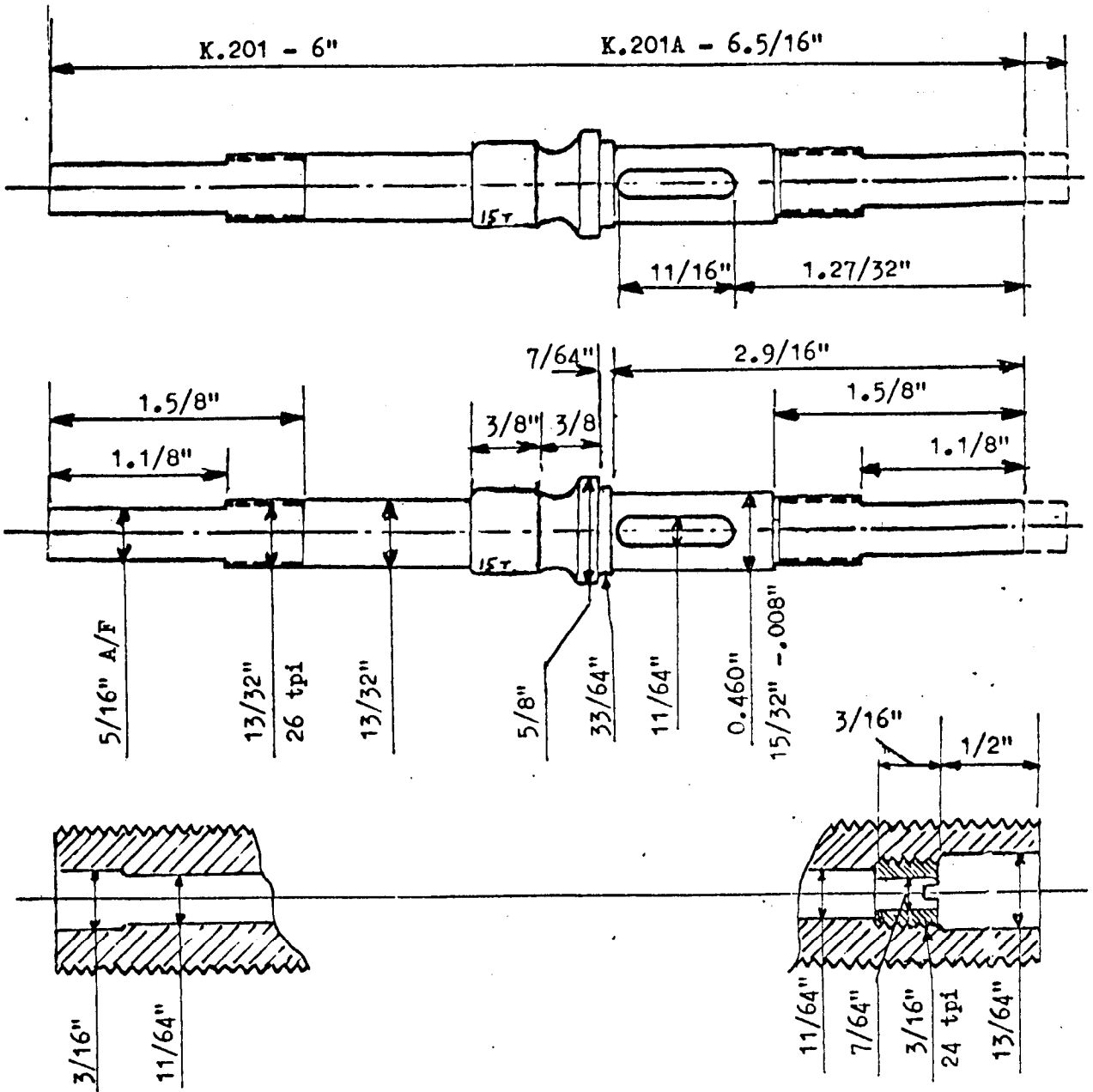

# MODELS T. & TF.

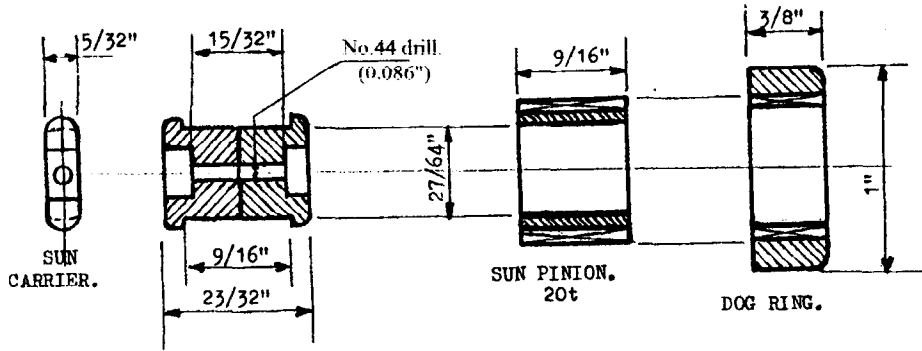
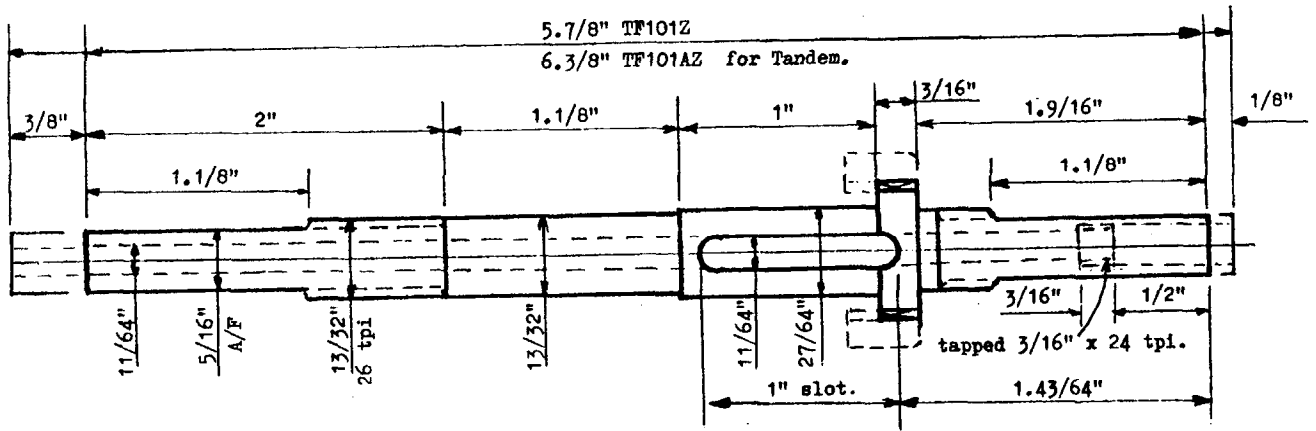

## INDICATOR for TANDEM, TF.126.

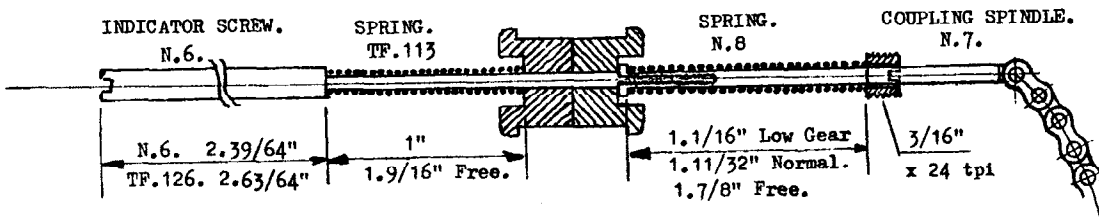

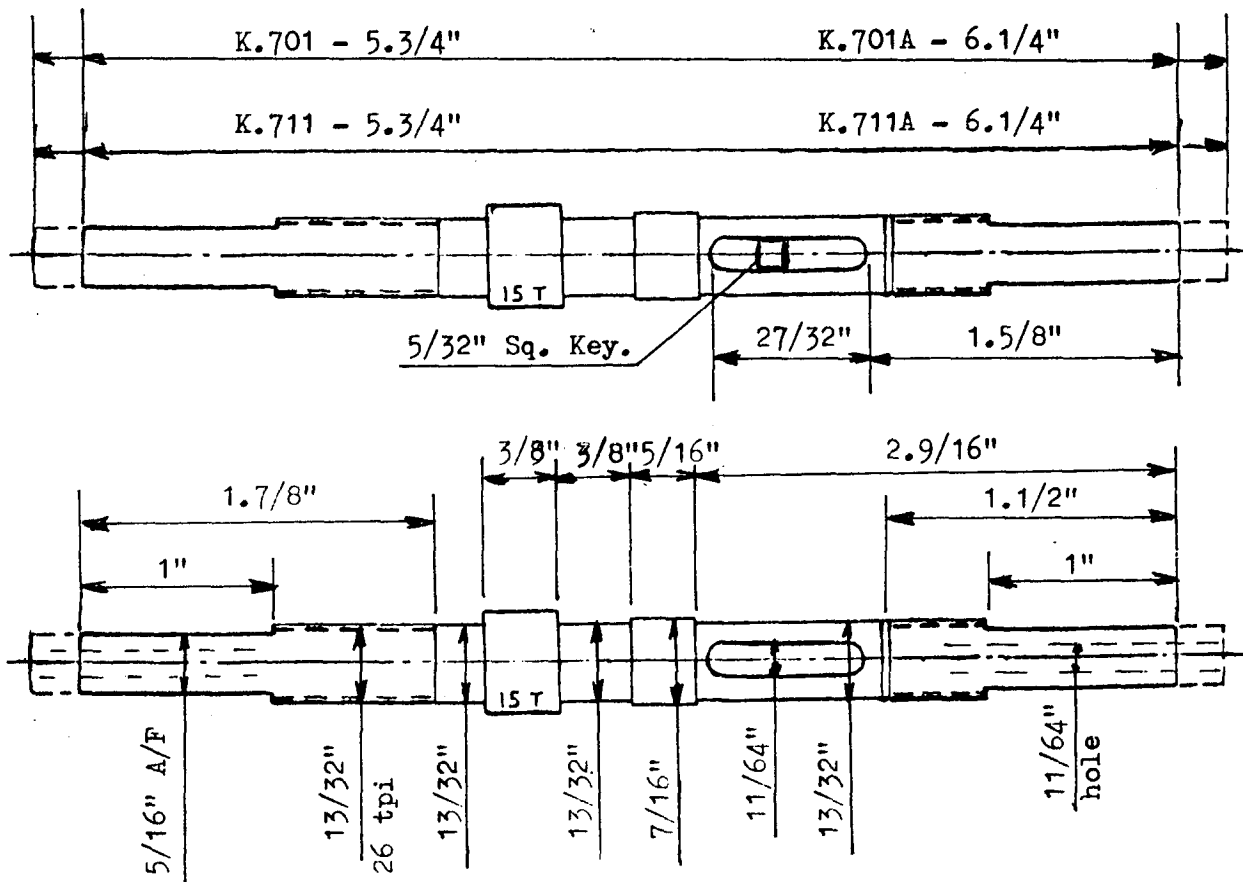

1937. K.701/701A - Indicator at RHS. with square key K.502.

1939. K.711/711A - Indicator at LHS. with square key K.502A.



1937 - 1939.

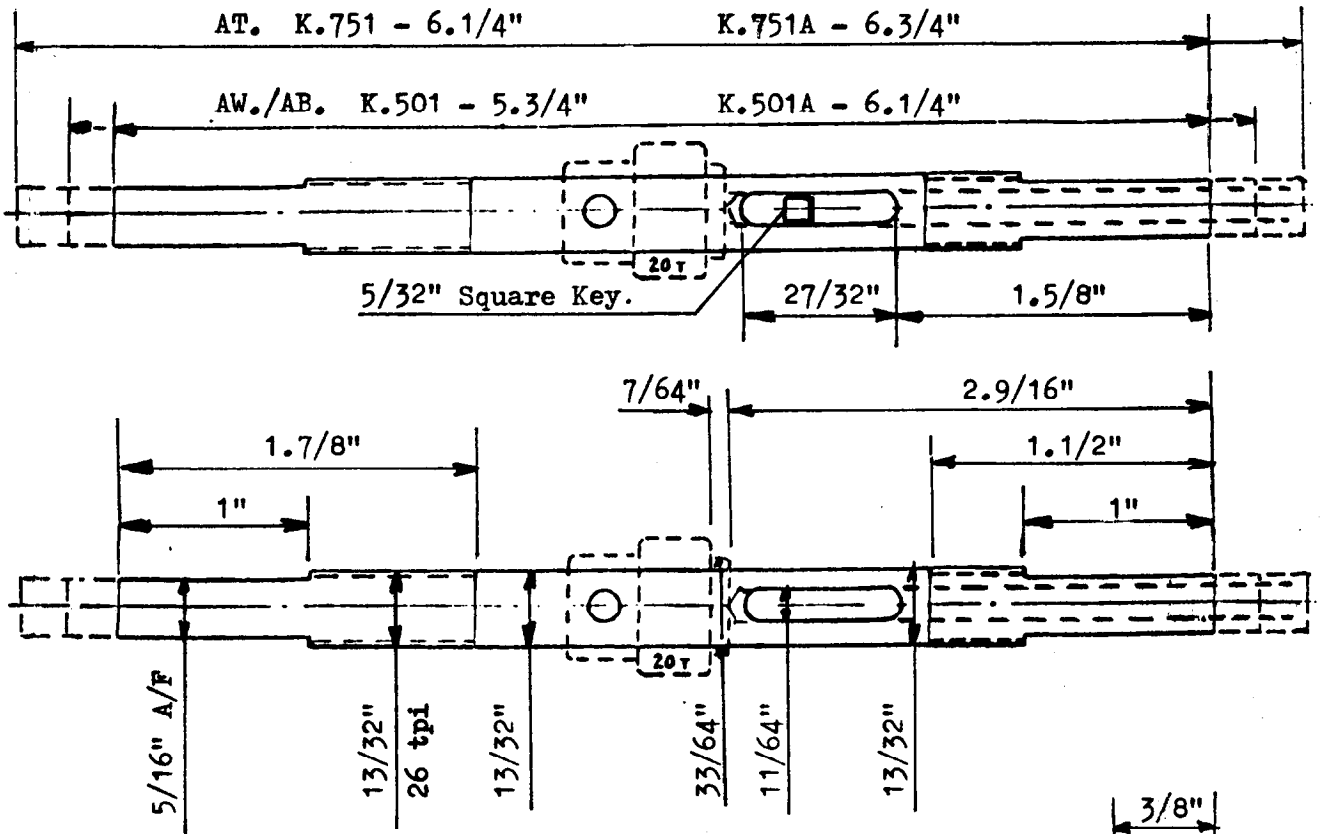

Axles drilled for Right hand indicator.

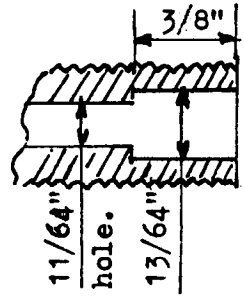

After 1940.

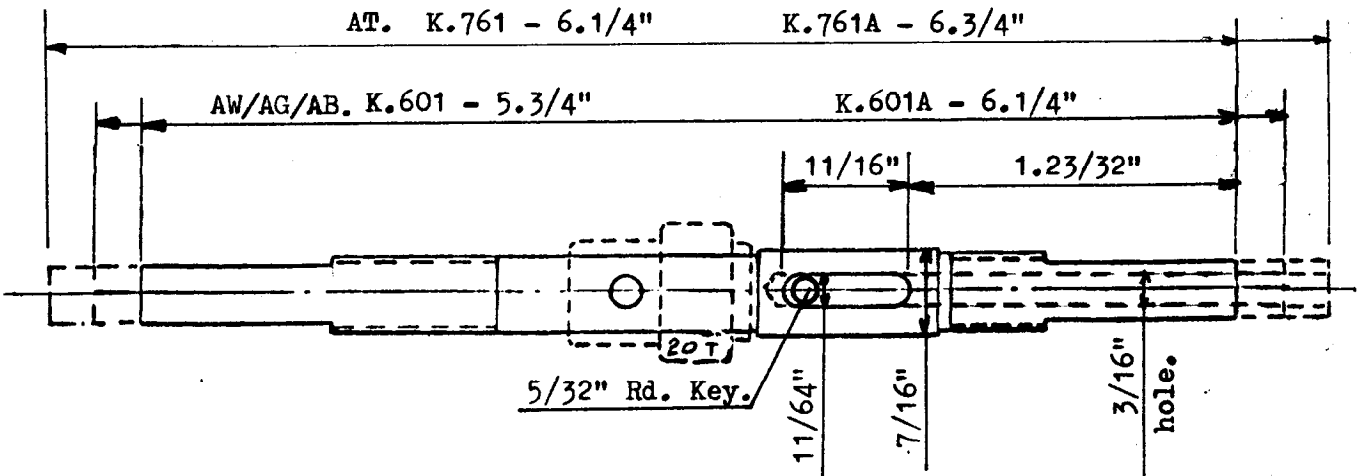

Axles drilled for Right hand indicator.

AM. 1938.

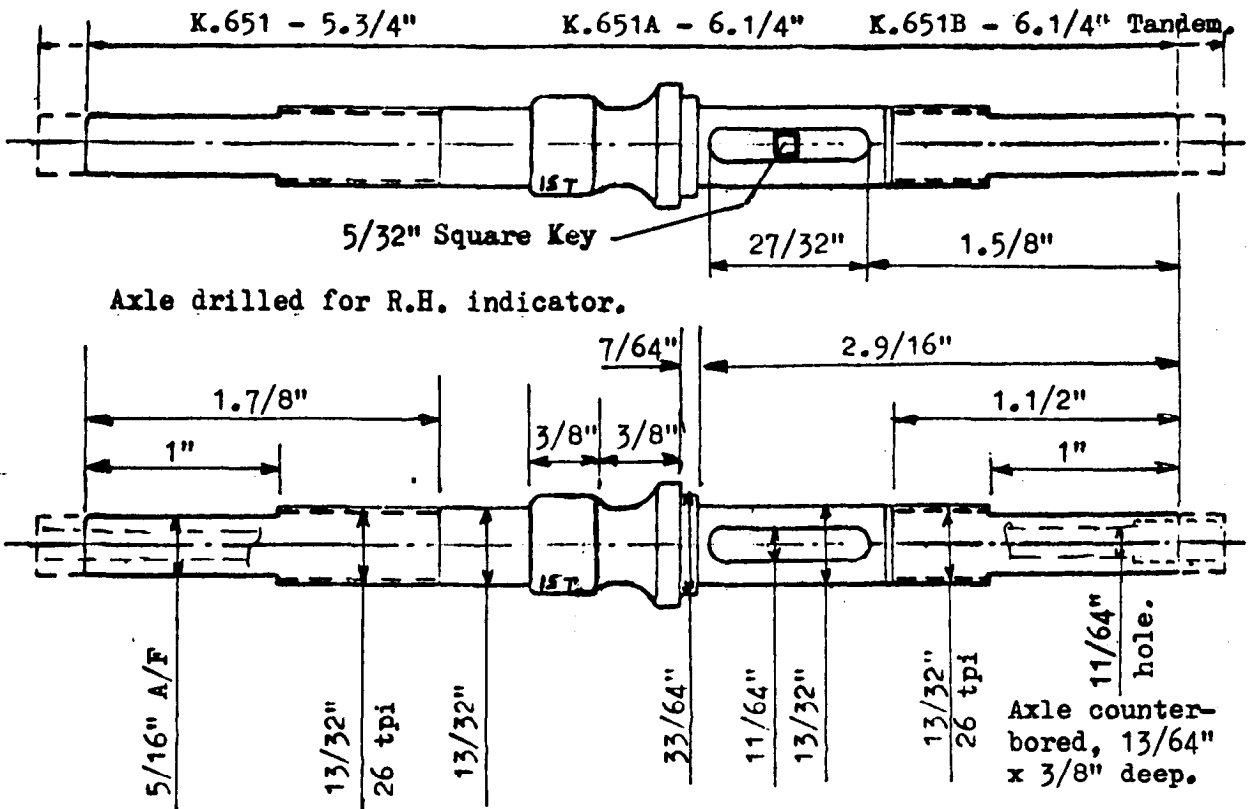

AM. 1939.

K.661 - 5.3/4" K.661A - 6.1/4"

Axle for AM 1939 same as 1938 but axle drilled for Left hand indicator.

AM. 1940 - 1959.

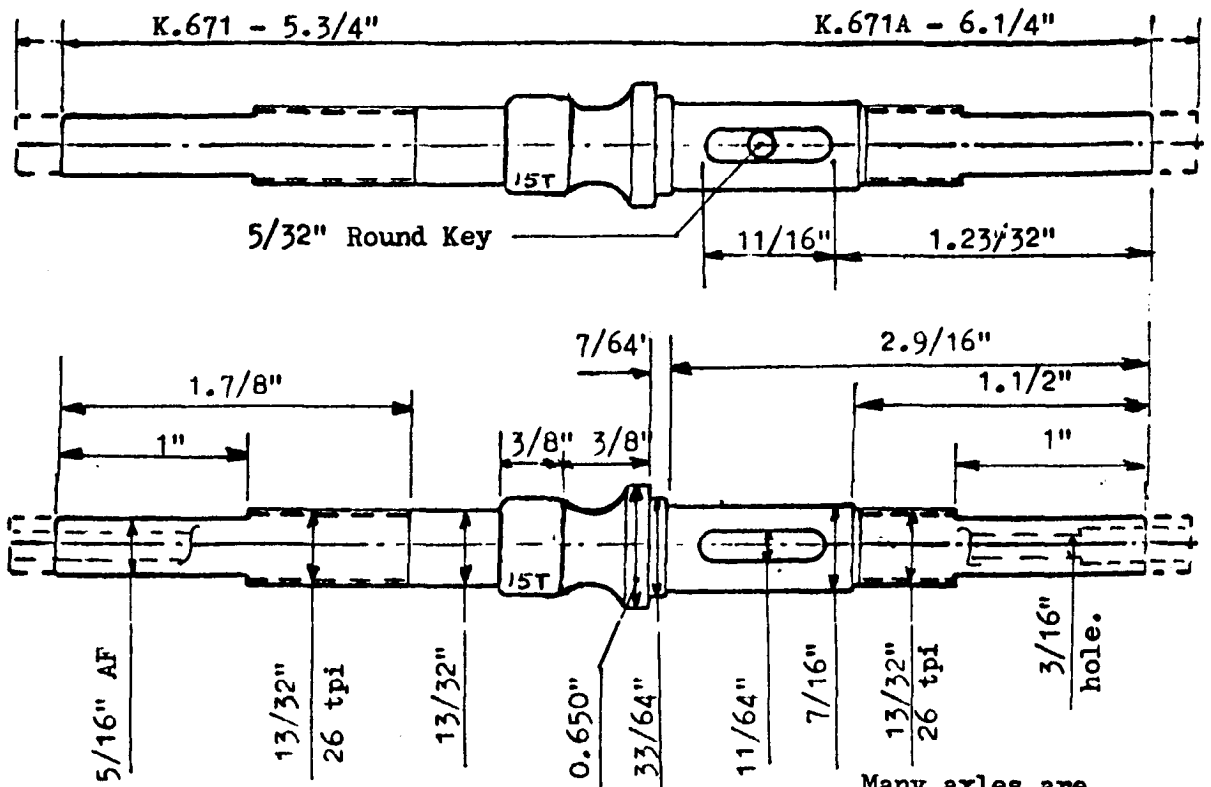

Axle drilled for Left hand indicator.

1938/9. AF & FM.

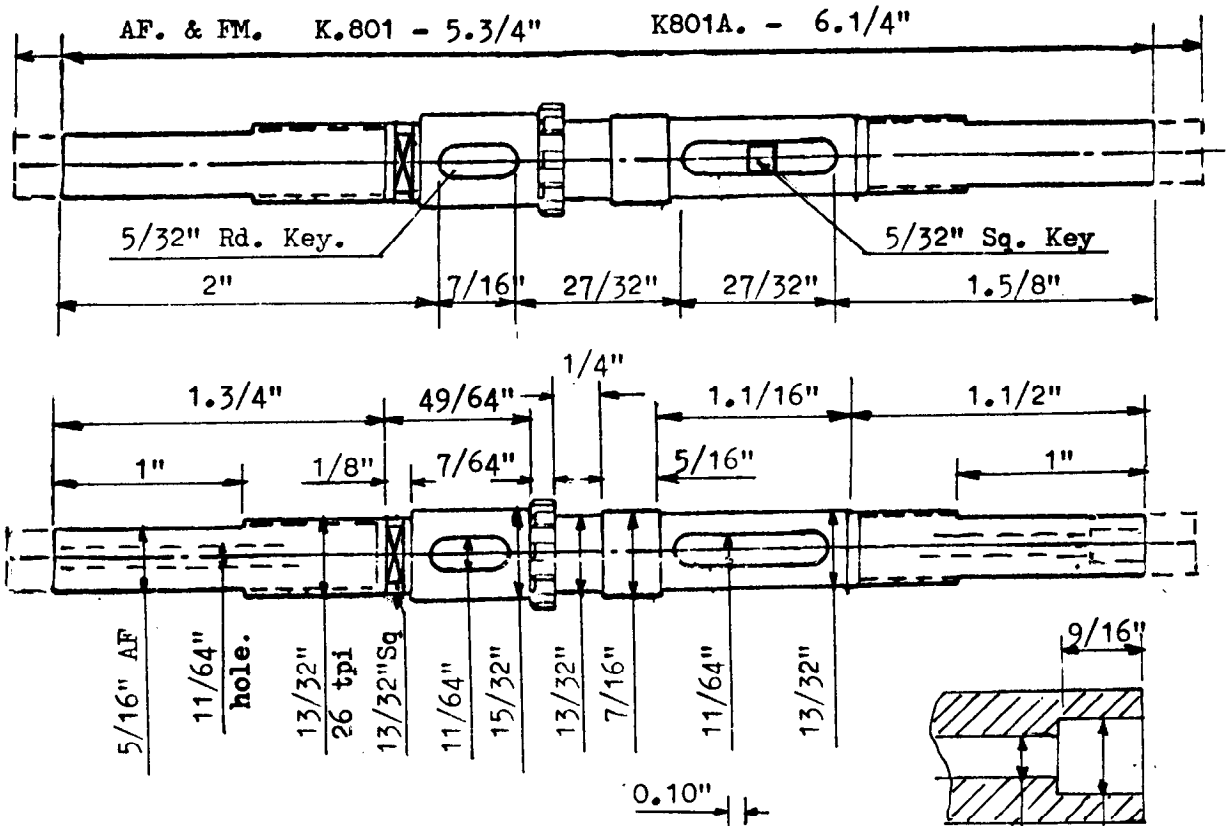

From 1940. AC. ASC. FC. & FM.

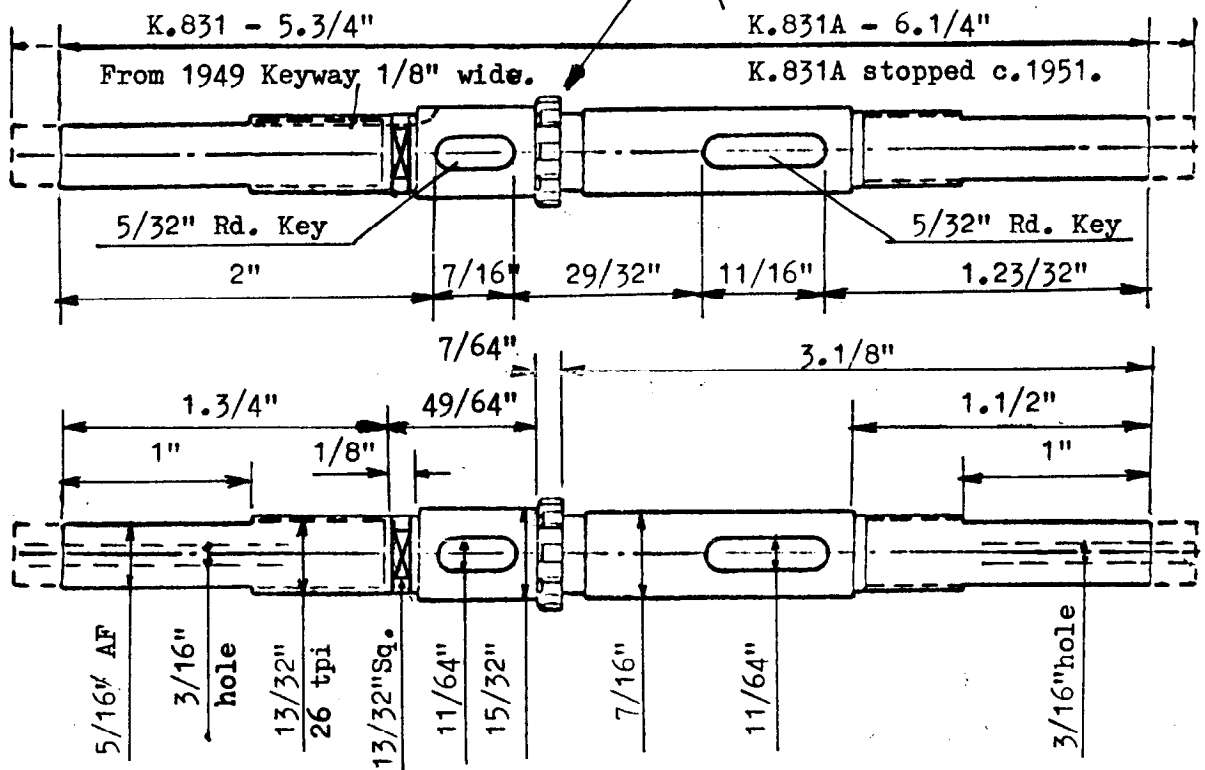

All axles drilled for Left hand indicator.

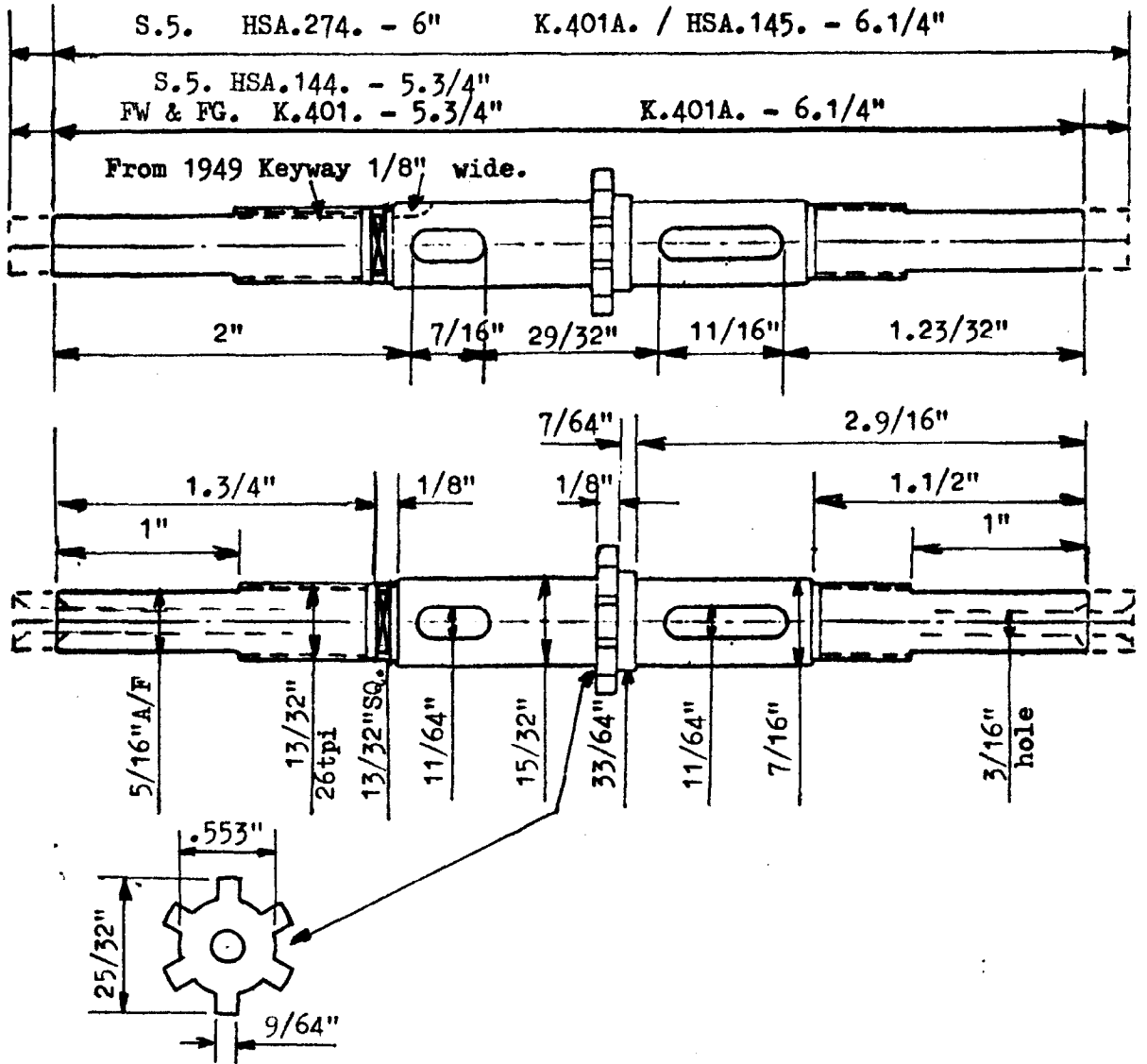

Axles drilled for Left hand indicator.

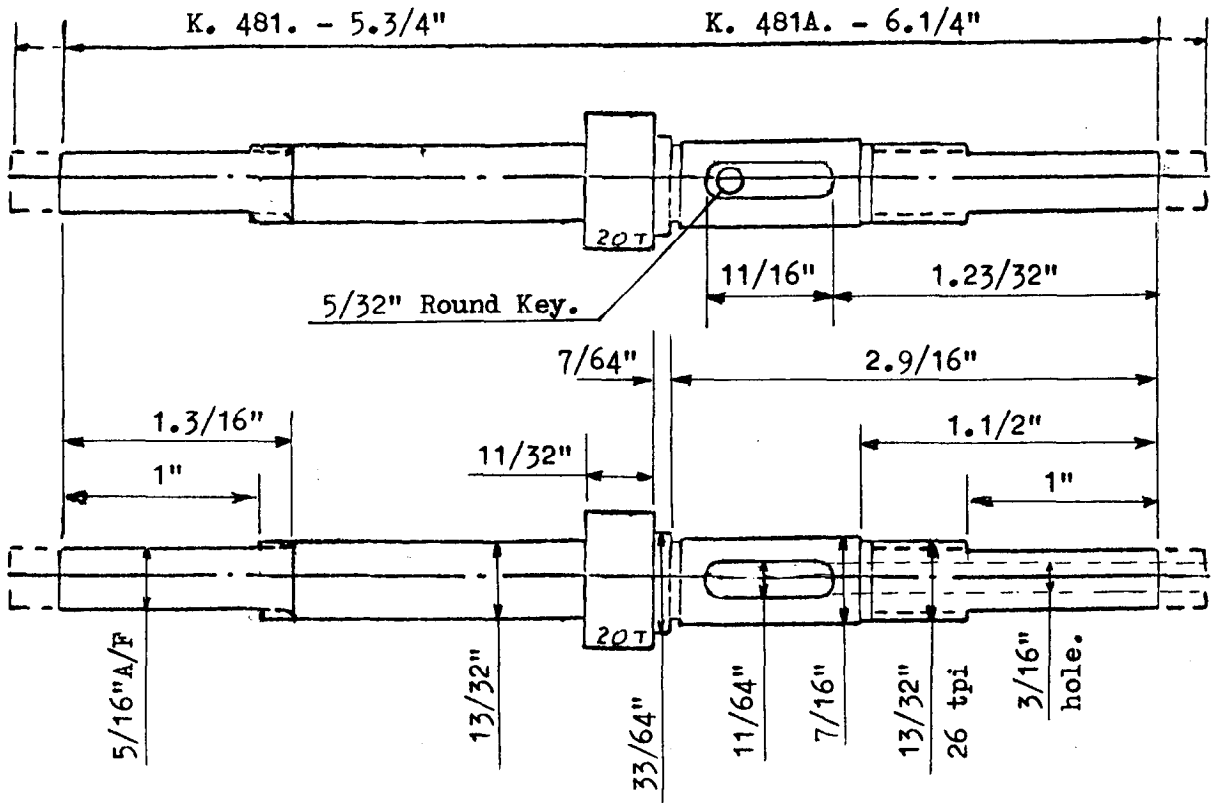

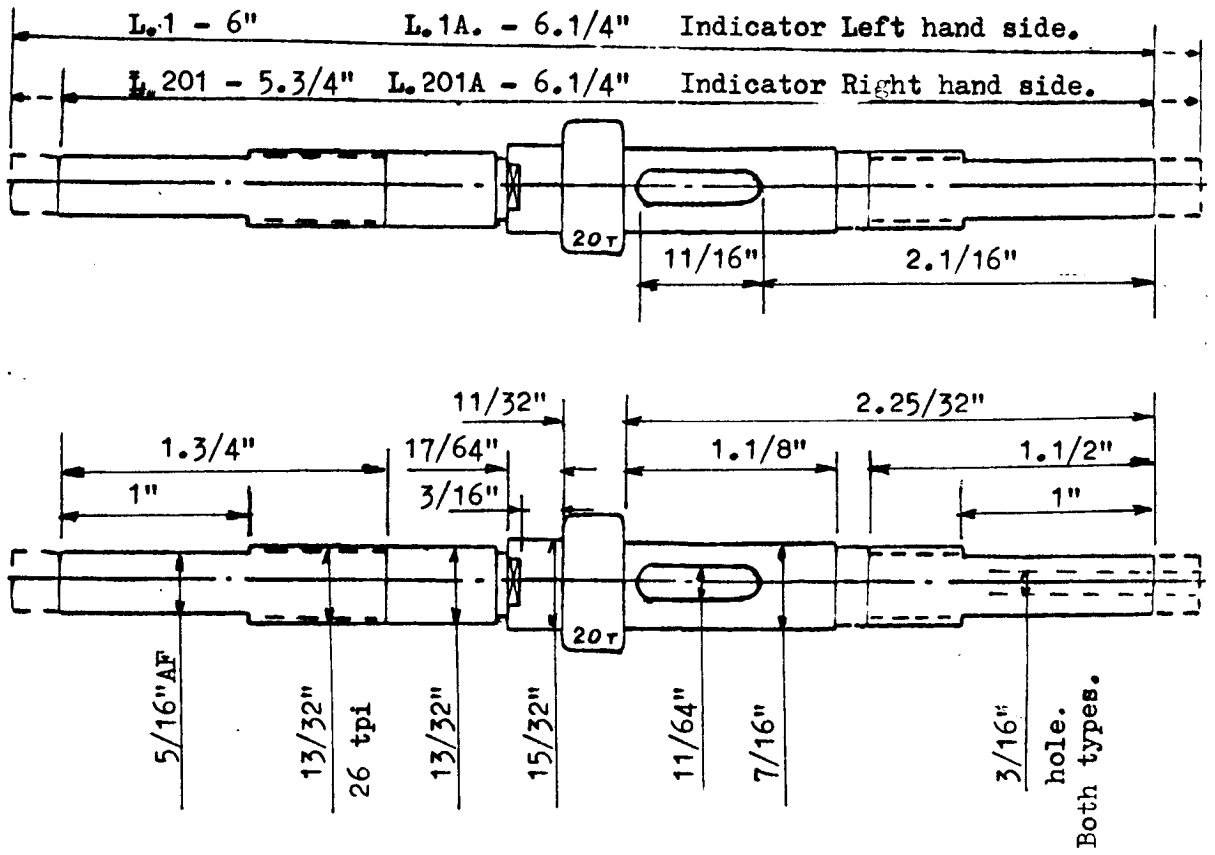

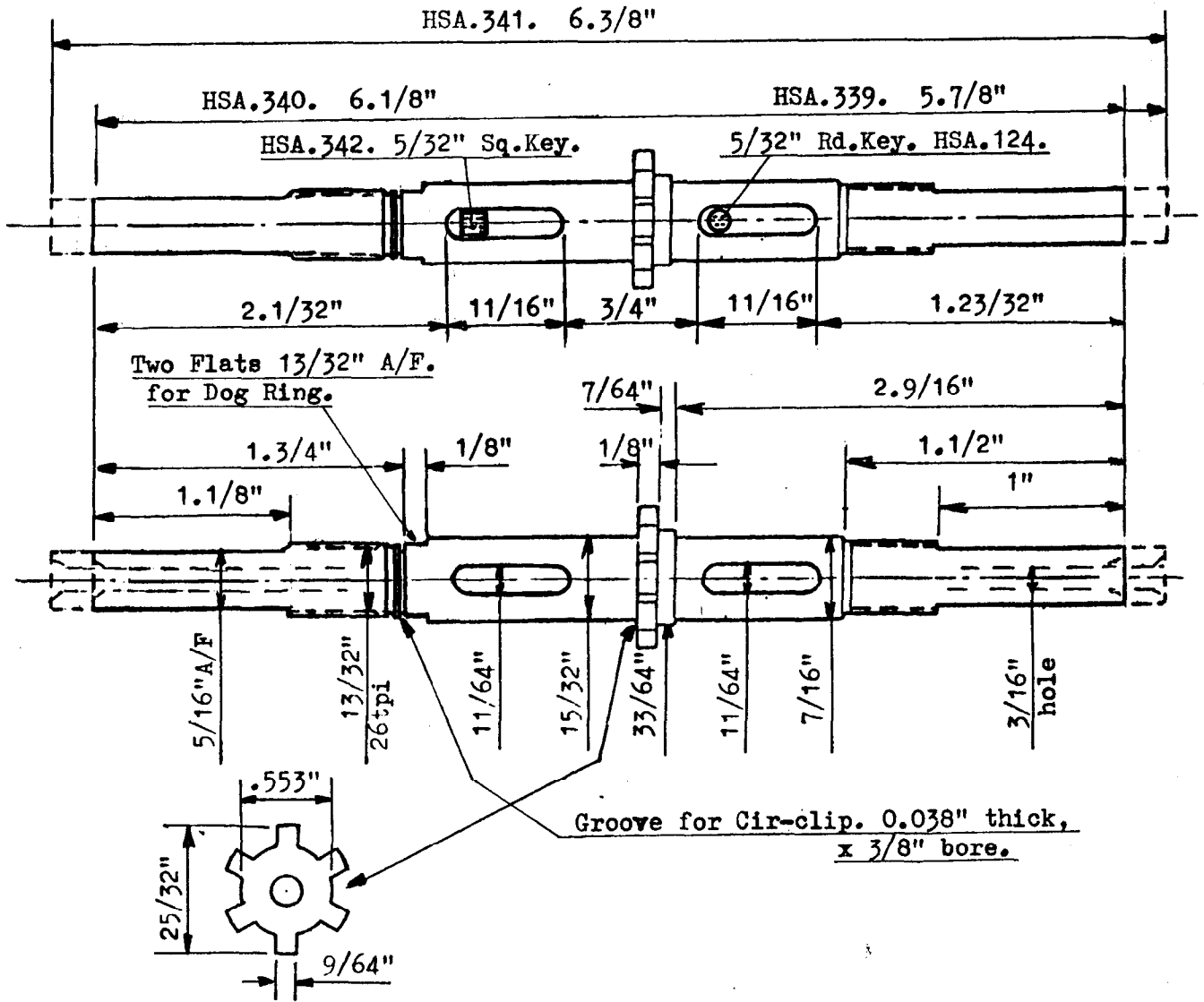

S5/2 & AT5 After 88 - 8

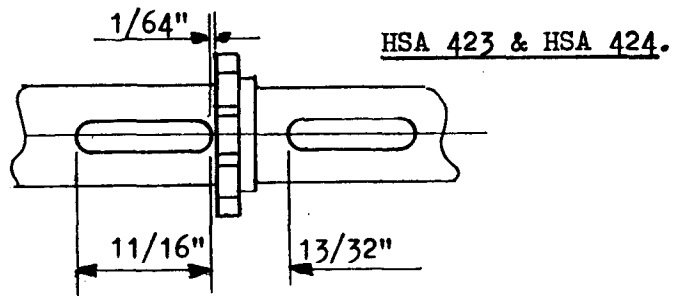

5 STAR HUB GEAR.

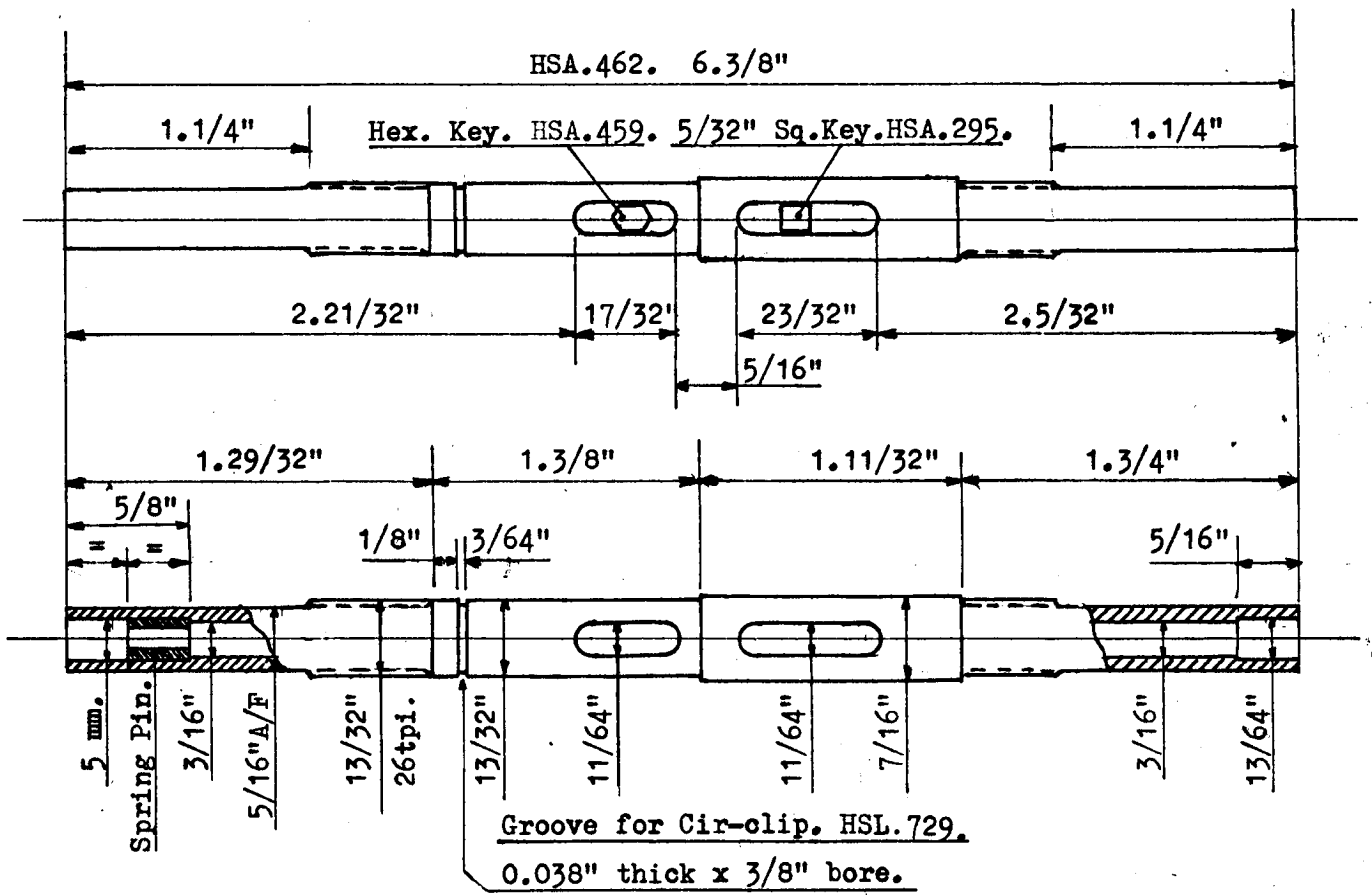



5 STAR HUB GEAR.

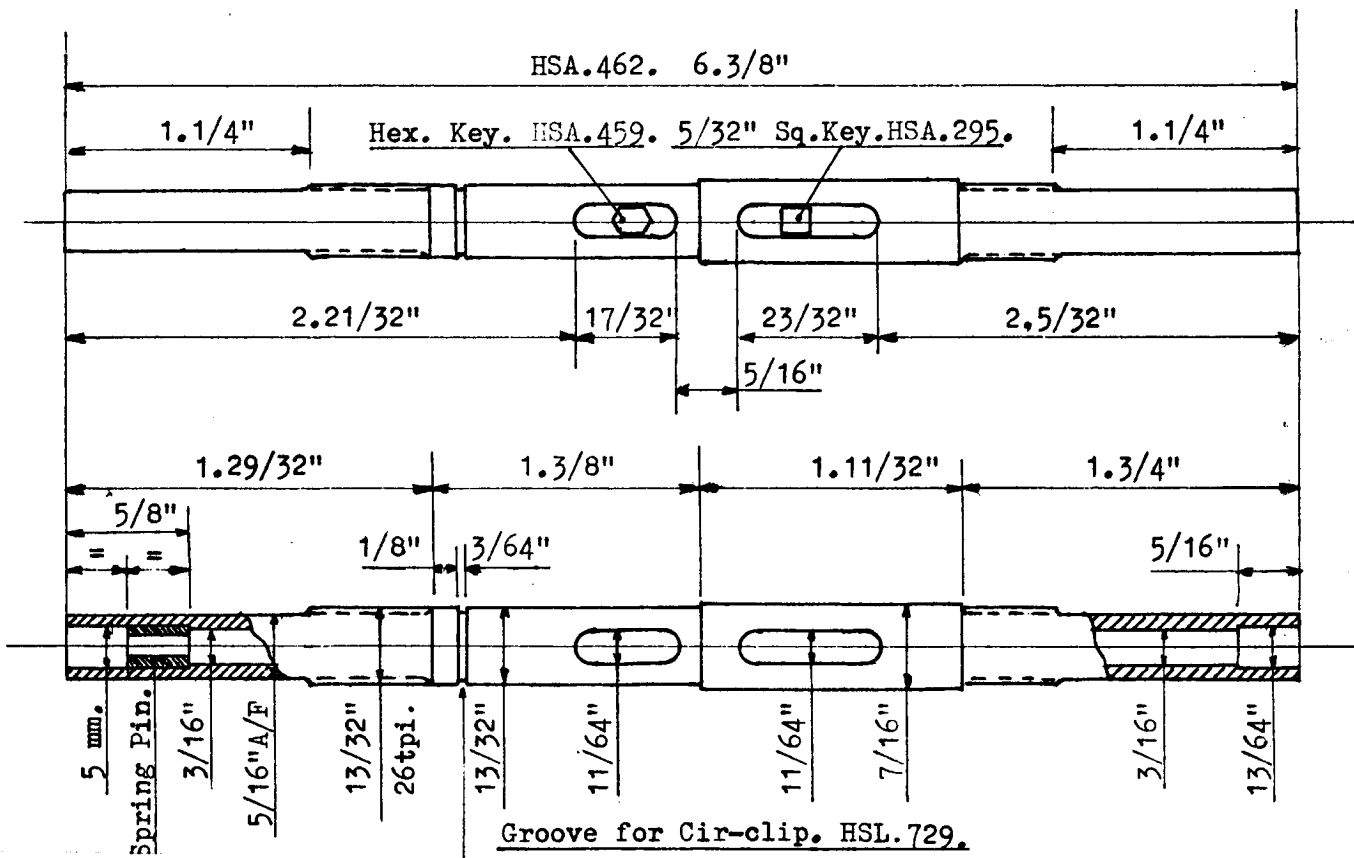

S5/2.

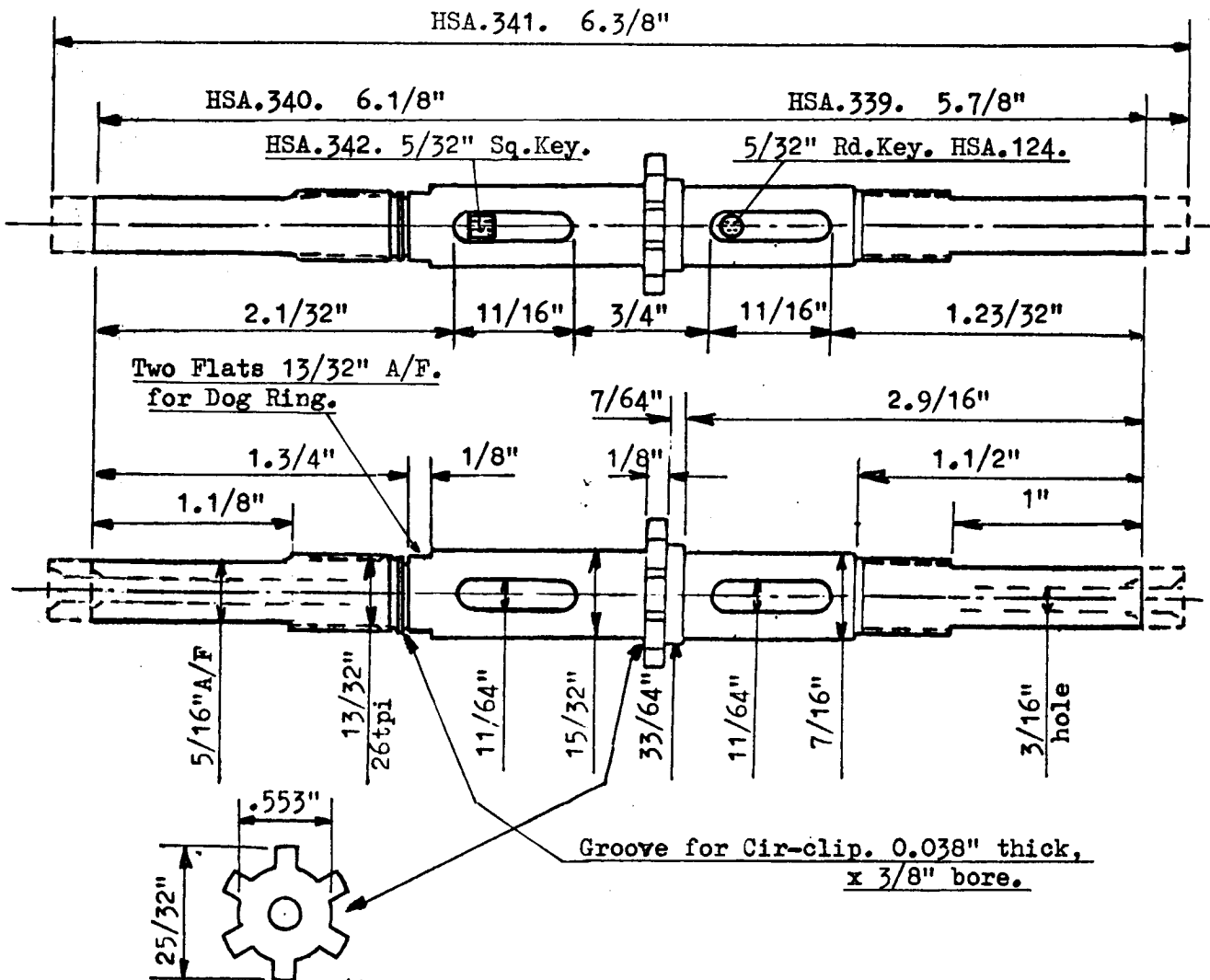

### SPRINTER 5.

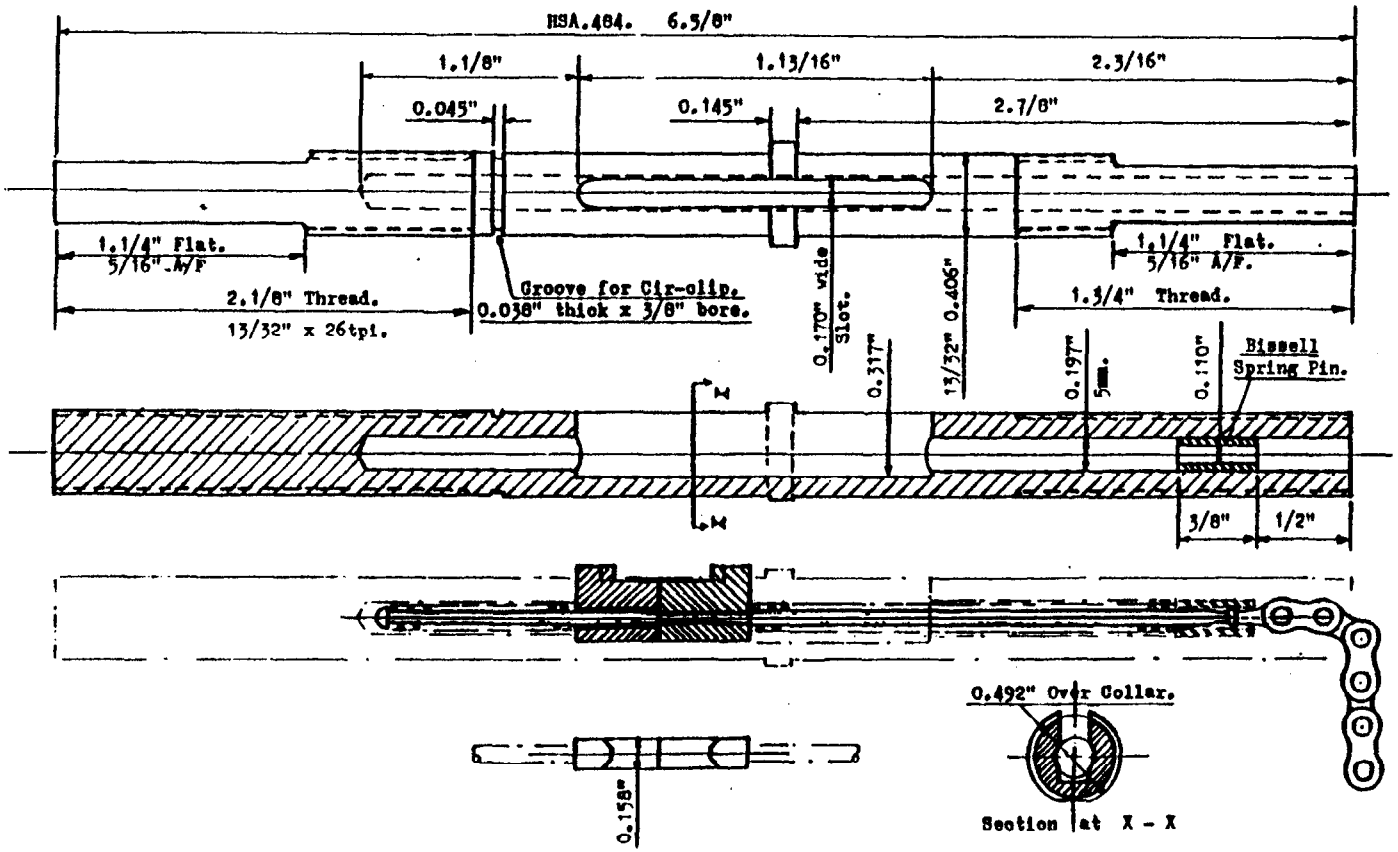

### SPRINTER 7.

