

FC Close-Ratio 4-SPEED HUB

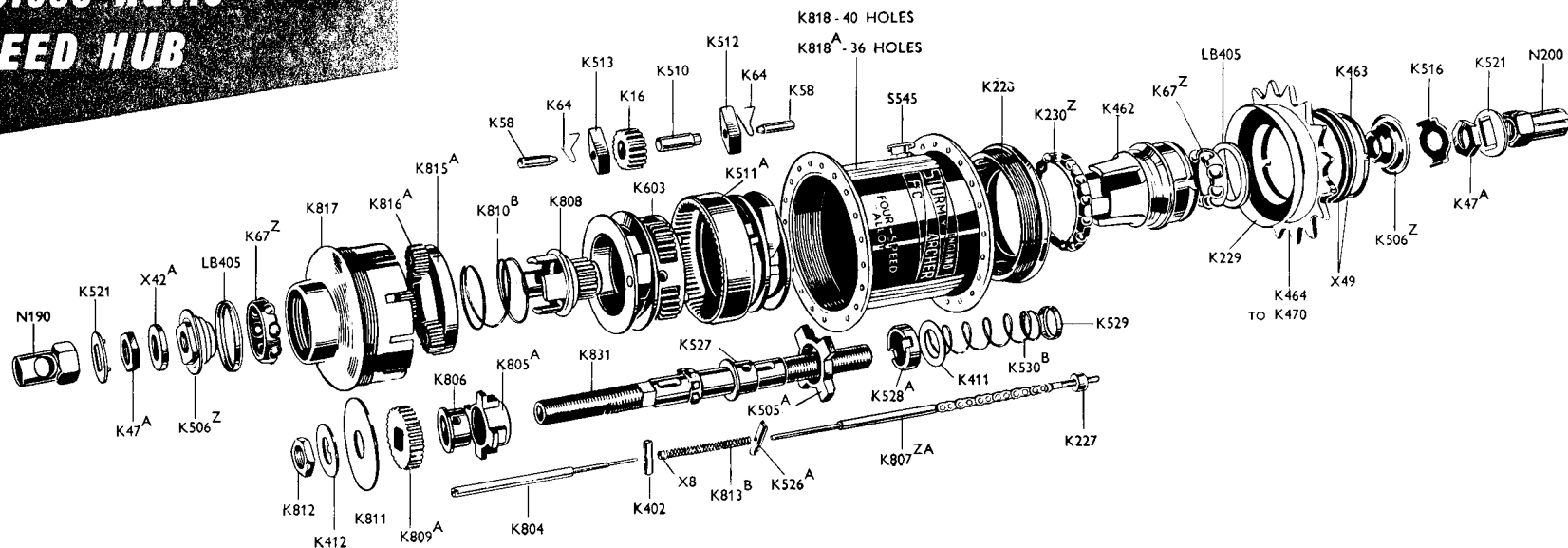

CODE No.

DESCRIPTION

K831	Axle, 5 $\frac{1}{4}$ " long
K805A	Low Gear Dog
K806	Dog Sleeve
K402	Low Gear Key
K809A	Secondary Sun Pinion
K811	Locating Plate
K412	Locking Washer
K812	Locknut
K815A	Secondary Planet Cage
K816A	Secondary Planet Pinion
K810B	Low Gear Spring
K808	Primary Sun Pinion
K603	Planet Cage
K513	Low Gear Pawl
K58	Pawl Pin
K64	Pawl Spring
K16	Planet Pinion
K510	Pinion Pin
K804	Indicator
X8	Collar for Compensator Spring
K813B	Compensator Spring
K527	Clutch Sleeve
K505A	Sliding Clutch
K526A	Axle Key
K807ZA	Coupling complete
K807Z	Coupling complete, quick-release type. <i>Not illustrated</i>
K740AZ	Quick-release Connection. <i>Not illustrated</i>
K528A	Thrust Ring
K411	Thrust Washer
K530B	Clutch Spring

CODE No.

DESCRIPTION

K529	Clutch Spring Cap
K511A	Gear Ring
K512	Gear Ring Pawl
K228	R.H. Ball Ring
K230Z	Ball Cage with $\frac{3}{16}$ " diam. balls
K462	Driver
K67Z	Ball Cage with 8 $\frac{1}{4}$ " diam. balls
LB405	Outer Dust Cap
K506Z	Axle Cone with Dust Cap
K516	R.H. Cone Locking Washer
K818	Shell, 40 holes
K818A	Shell, 36 holes
S545	Lubricator
K817	L.H. Ball Cup
K227	Connection Locknut
X42A	Axle Spacing Washer
K47A	Cone Locknut
K521	Axle Locking Washer
N190	L.H. Axle Nut
N200	R.H. Axle Nut
K229	Sprocket Dust Cap
K464	Sprocket, 14 teeth
K465	Sprocket, 15 teeth
K466	Sprocket, 16 teeth
K467	Sprocket, 17 teeth
K468	Sprocket, 18 teeth
K469	Sprocket, 19 teeth
K470	Sprocket, 20 teeth
X49	Sprocket Spacing Washer
K463	Circlip

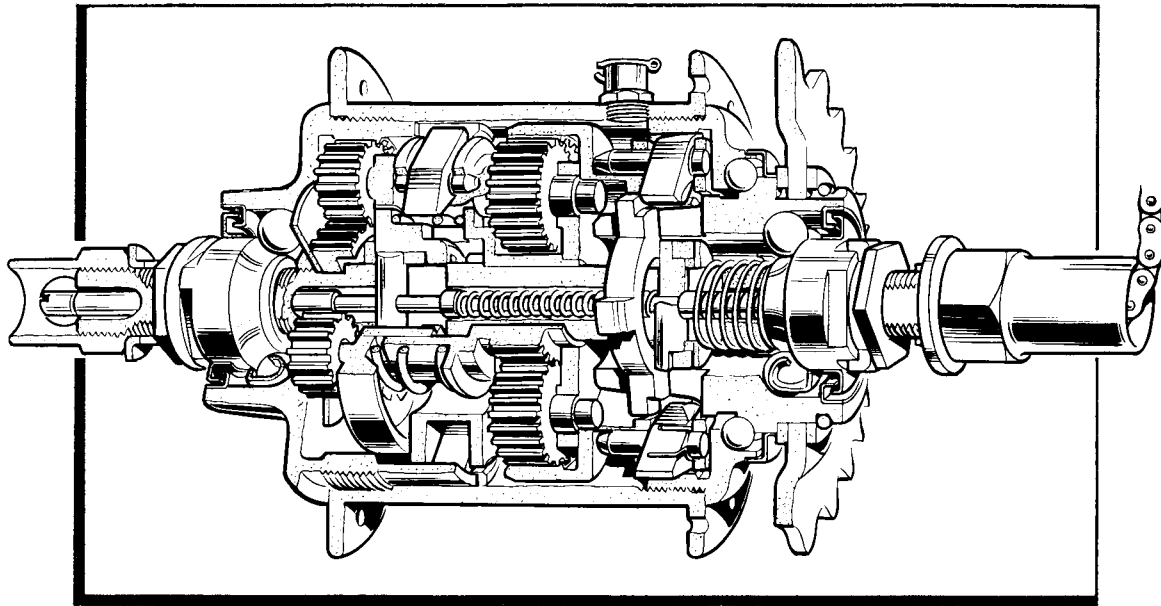

TO RE-ASSEMBLE THE FC HUB

Proceed as follows:

1. If the left-hand ball cup has been removed from the hub shell, replace it by screwing anti-clockwise because it has a left-hand thread, using the special tool, DD11182, which enters from the right-hand end. The teeth of the tool and the cup must be in full engagement.
2. Prepare the following preliminary sub-assemblies:
 - a. Fit the ball cage into the left-hand ball cup, with the ring of the ball-retainer facing outwards and the recess in the dust cap also facing outwards. If a new ball-retainer is being fitted, the dust cap also should be new.
 - b. Fit the ball cage into the driver with the ring of the ball-retainer facing outwards and the recess in the dust cap also facing outwards. If a new ball-retainer is being fitted, the dust cap also should be new. If the sprocket has been removed see No. 28 below.
 - c. Fit the pawls, pins and springs into the gear ring as described in the general instructions to 'The Re-assembling of Sturmey-Archer Hubs.'
 - d. Fit the pawls, pins and springs to the planet cage as described

in the general instructions to 'The Re-assembling of Sturmey-Archer Hubs.'

- e. Smear grease in the channels of the dust caps of the left-hand ball cup and the driver and in the recess of the right-hand ball ring. *Do not use grease anywhere else.*
3. Hold the axle in a vice, with the smaller slot uppermost, and fit the low-gear clutch sleeve, with its flange on top.
4. Slip the small low-gear key through the holes of the low-gear clutch sleeve, making sure that the hole through the key is in line with the bore of the axle. Hold the key temporarily in position by dropping the indicator rod down the axle and through the key.
5. Holding the indicator rod in position with one finger, remove the axle from the vice and hold it the other way up. Fit the low-gear clutch on to the axle, with the four dogs pointing downwards.
6. Fit the large low-gear spring and the primary sun pinion, with its four large legs pointing downwards and so engaging the low-gear clutch. (The low-gear spring, the compensating spring, and the clutch spring must be of the same series. If one has to be replaced, the other two must be.)
7. Slip the indicator rod out of the axle (the low-gear clutch key will now stay in position) and put the axle back in the vice.

8. Fit the primary planet cage complete.
9. Drop the compensating spring down the axle, collar first.
10. Fit the clutch sleeve (flange first) and the sliding clutch with recess over the flange of the sleeve.
11. Lift the clutch sleeve and the clutch up to the top of the long axle slot and insert axle key through the clutch sleeve, making sure that the two flats on the key are facing upwards.
12. Fit the indicator coupling by passing the rod down the axle, through the axle key, and into the compensator spring. Note that the indicator coupling must always be fitted before the indicator rod.
13. Remove the axle from the vice and push the indicator rod into the left-hand end of the axle. Press the assembled mechanism down on a flat surface to force the indicator rod into the axle, at the same time pressing down on the sliding clutch. Then rotate the indicator chain to screw it to the indicator rod. When the chain is felt to be fully screwed home insert a *small* screwdriver into the slot of the indicator rod and exert a *slight* extra pressure on the chain, to make sure that the indicator and the rod are both fully screwed together, taking care not to twist off the small threaded end.
14. Fix the axle in the vice again and make sure that the clutch slides quite freely on the axle when the indicator chain is moved up and down.
15. Fit the thrust collar, making sure that both slots fit over the flats of the axle key. Add the thrust washer.
16. Fit the gear ring, the ball ring (with ball cage), the driver, the axle spring and the clutch spring cap, in that order.
17. Fit the right-hand cone and screw it up *finger-tight*. Then slacken it back half a turn and lock it in that position with the special washer and locknut. On no account must the cone be unscrewed more than half a turn, as that would throw the gear mechanism out of adjustment.
18. Remove the assembled mechanism from the vice and replace it the other way up.
19. Fit the secondary planet cage, with the pins upwards and the slots engaging the limbs of the low-gear dogs.
20. Fit the secondary planet pinions.
21. Fit the secondary sun pinion, with the recess downwards, so that the sun pinion engages with the square flats on the axle.
22. Fit the locating plate and tab washer and tighten the locknut. Turn over the edge of the washer on two opposite sides of the locknut.
23. Remove the assembled mechanism from the vice, hold it vertically with the planet cage uppermost and pour about two teaspoonfuls of good quality thin oil into the cage.
24. Insert the assembled mechanism into the hub shell and screw up the right-hand ball ring finger-tight only.
25. Make sure that the marks put on the ball ring and the hub flange before dismantling will register properly, and then screw up tightly.
26. Fit the left-hand cone, washer, and locknut in the arrangement noted when dismantling, and adjust the hub as described in 'The Fitting and Adjustment of Sturmey-Archer Hubs.'
27. Fit any special washers noted when dismantling the hub.
28. If the sprocket has been removed from the driver, fit the outer dust cap over the driver before replacing the sprocket, and see that the dust cap is properly centred on the flange of the driver. Replace the sprocket and the spacing washers in the arrangement noted when dismantling, and add the circlip.
29. Replace the wheel in the cycle frame and adjust the gear as described in 'The Fitting and Adjustment of Sturmey-Archer Hubs.'

STURMEY
ARCHER